

Varilog™ 28000 MS

Control Valve

Appendix to 28000 Series VariPak™ Manual ref 30857

Instruction Manual (Rev.B)

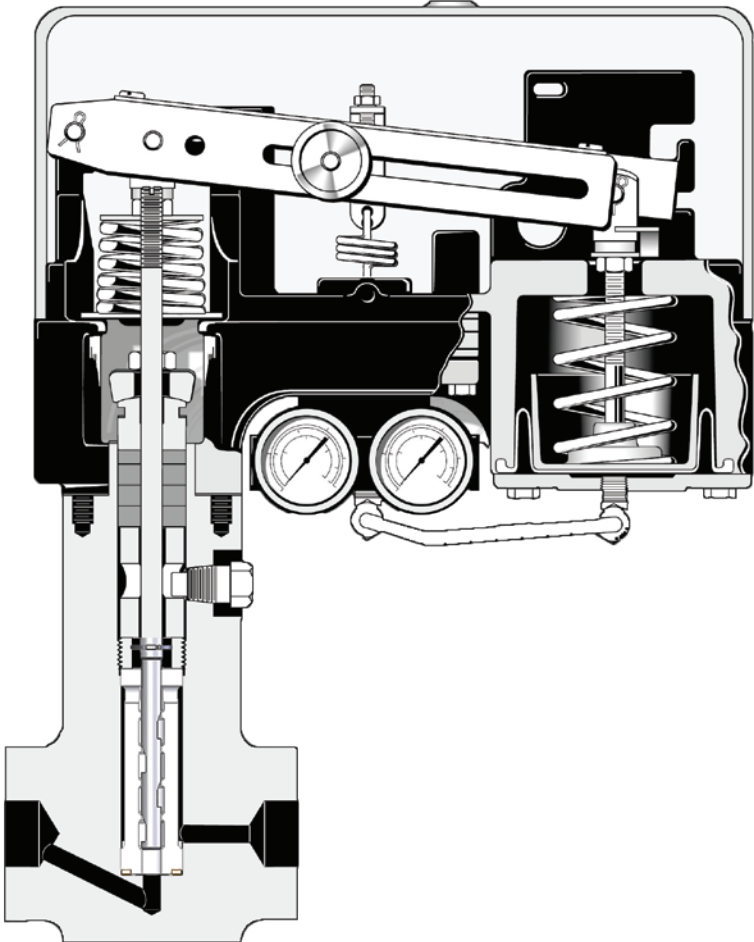

THESE INSTRUCTIONS PROVIDE THE CUSTOMER/OPERATOR WITH IMPORTANT PROJECT-SPECIFIC REFERENCE INFORMATION IN ADDITION TO THE CUSTOMER/OPERATOR'S NORMAL OPERATION AND MAINTENANCE PROCEDURES. SINCE OPERATION AND MAINTENANCE PHILOSOPHIES VARY, BAKER HUGHES COMPANY (AND ITS SUBSIDIARIES AND AFFILIATES) DOES NOT ATTEMPT TO DICTATE SPECIFIC PROCEDURES, BUT TO PROVIDE BASIC LIMITATIONS AND REQUIREMENTS CREATED BY THE TYPE OF EQUIPMENT PROVIDED.

THESE INSTRUCTIONS ASSUME THAT OPERATORS ALREADY HAVE A GENERAL UNDERSTANDING OF THE REQUIREMENTS FOR SAFE OPERATION OF MECHANICAL AND ELECTRICAL EQUIPMENT IN POTENTIALLY HAZARDOUS ENVIRONMENTS. THEREFORE, THESE INSTRUCTIONS SHOULD BE INTERPRETED AND APPLIED IN CONJUNCTION WITH THE SAFETY RULES AND REGULATIONS APPLICABLE AT THE SITE AND THE PARTICULAR REQUIREMENTS FOR OPERATION OF OTHER EQUIPMENT AT THE SITE.

THESE INSTRUCTIONS DO NOT PURPORT TO COVER ALL DETAILS OR VARIATIONS IN EQUIPMENT NOR TO PROVIDE FOR EVERY POSSIBLE CONTINGENCY TO BE MET IN CONNECTION WITH INSTALLATION, OPERATION OR MAINTENANCE. SHOULD FURTHER INFORMATION BE DESIRED OR SHOULD PARTICULAR PROBLEMS ARISE WHICH ARE NOT COVERED SUFFICIENTLY FOR THE CUSTOMER/OPERATOR'S PURPOSES THE MATTER SHOULD BE REFERRED TO BAKER HUGHES.

THE RIGHTS, OBLIGATIONS AND LIABILITIES OF BAKER HUGHES AND THE CUSTOMER/OPERATOR ARE STRICTLY LIMITED TO THOSE EXPRESSLY PROVIDED IN THE CONTRACT RELATING TO THE SUPPLY OF THE EQUIPMENT. NO ADDITIONAL REPRESENTATIONS OR WARRANTIES BY BAKER HUGHES REGARDING THE EQUIPMENT OR ITS USE ARE GIVEN OR IMPLIED BY THE ISSUE OF THESE INSTRUCTIONS.

THESE INSTRUCTIONS ARE FURNISHED TO THE CUSTOMER/OPERATOR SOLELY TO ASSIST IN THE INSTALLATION, TESTING, OPERATION, AND/OR MAINTENANCE OF THE EQUIPMENT DESCRIBED. THIS DOCUMENT SHALL NOT BE REPRODUCED IN WHOLE OR IN PART WITHOUT THE WRITTEN APPROVAL OF BAKER HUGHES.

As the **Masoneilan™** Varilog Series valve is a variant of the 28000 Series Varipak control valve, the instructions mentioned in Manual 30857 are applicable, in addition to the specifications provided in this Appendix.

Sectional Drawing - Standard Varilog

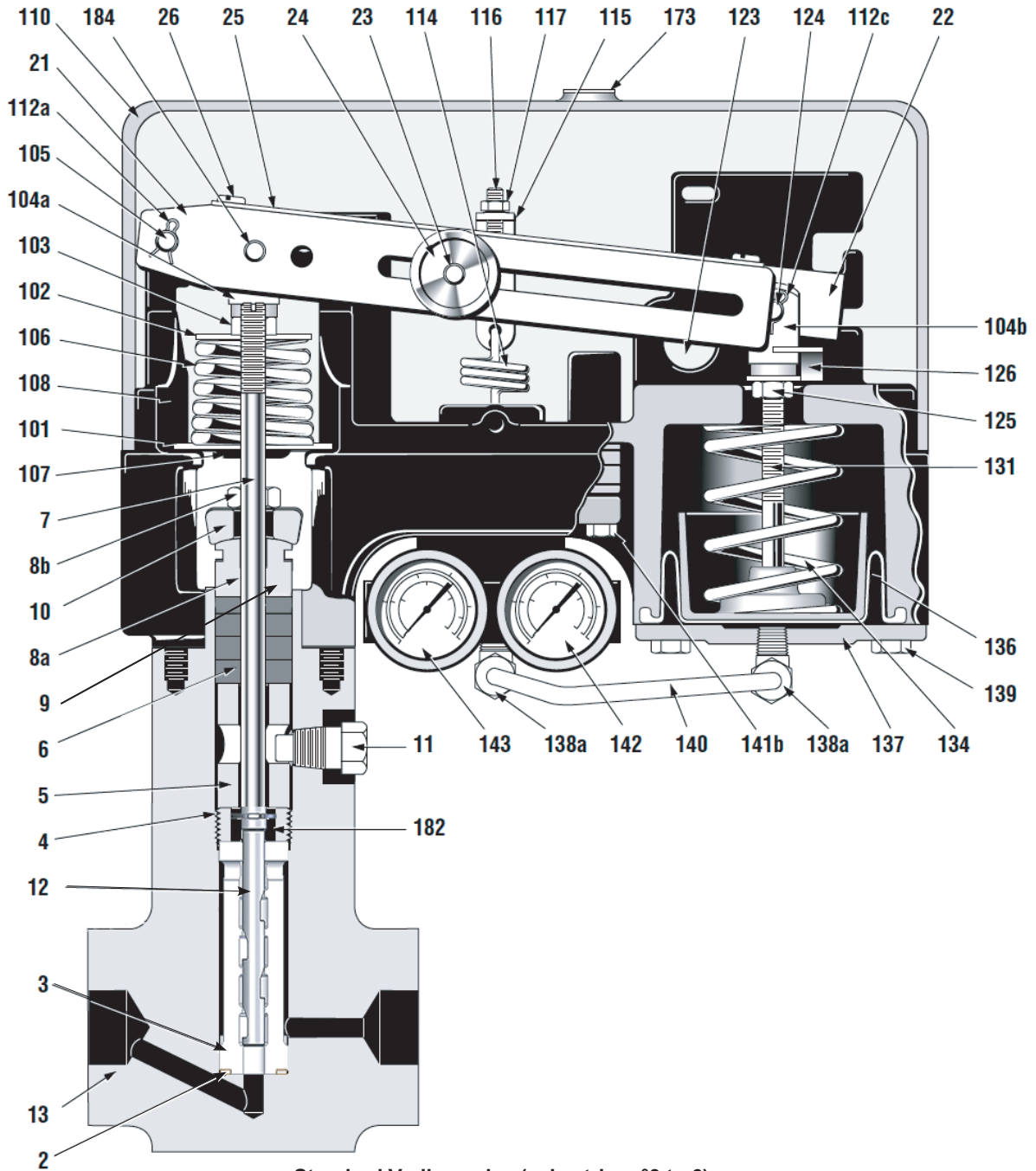

Parts List

Notes hereunder are referring to Figures from VariPak 28000 Series Instruction Manual (Ref. 30857).

Ref.	Qty	Part Name	Ref.	Qty	Part Name	Ref.	Qty	Part Name
△□	1	1/4" NPT pipe plug	101	1	Grommet support plate	◆	140	1 Tubing
○	2	Seat-ring gasket	102	1	Spring button	◆	141 (a, b)	4 Screw
	a	1 Seat ring C _v max. 3.8	103	1	Locknut	◆	142	1 Output gauge
	b	1 Seat ring C _v max. 2.3 and 1.2	104 (a, b)	2	Clevis	◆	143	1 Instrument gauge
◎	3	1 Seat ring C _v max. 0.25 and 0.60	105	1	Pivot pin No. 1	◆	144	1 Manifold block
	d	1 Seat ring C _v max. 0.10	106	1	Conical compression spring	◆	145	1 to 5 Shim
□	e	1 Seat ring C _v max. < 0.10	○ 107	1	Grommet	○ ◆	146	1 Gasket (includes 171 & 172)
□	f	1 Spacer C _v max. < 0.10	108	1	Actuator bracket	◆	147	1 Positioner block
4		1 Seat-ring retainer	109	2	Cover screw	◆	148	2 Slotted flat. c screw
5		1 Packing spacer	110	1	Cover	○ ◆	152	1 Positioner diaphragm S/A
○	6	1 Packing ring	◆ 112 (a, b, c)	6	Retainer clip	○ ◆	153	1 O-ring
7		2 Packing flange stud	◇ ◆ 114	1	Balance spring	▼ ◆	154	1 Spring
8	a	2 Mounting nut	◆ 115	1	Spring clamp	○ ◆	155	1 Sleeve
8	b	2 Packing flange nut	◆ 116	1	Take-up screw	○ ◆	156	1 Spool
9		1 Packing follower	◆ 117	1	Locknut	○ ◆	157	1 Spring
10		1 Packing flange	★ 118	1	Handwheel locknut	◆	158	1 Spring
11		1 Safety pin	★ 119	1	Handwheel bushing	△	159	2 Switch
	a	1 Plug/stem C _v max. 3.8	★ 120	1	Handwheel	△	160	4 Screw
	b	1 Plug/stem C _v max. 2.3	★ 121	1	Handwheel lock	△	161	4 Washer
◎	c	1 Plug/stem C _v max. 1.2 & 0.6	★ 122	1	Lever arm stop	△	162	4 Nut
	d	1 Plug/stem C _v max. 0.25 & 0.10	123	1	Pipe plug	△	163	4 Wire
13	a	1 Body C _v max. < 3.8	124	1	Pivot pin No. 4	△	164	1 Terminal
13	b	1 Body C _v max. 3.8	125	1	Locknut	■	165	2 Logo
18		1 Pivot pin No. 3 (22/108)	126	1	Indicator	■	168	1 Cover washer
20		1 I/P module	127	1	Indicator plate	◆	170	2 Signal decal
21		1 Lever No. 1	129	2	Indicator plate screw	■ ◆	171	1 O-ring
22		1 Lever No. 2	130	2	Speed nut	■ ◆	172	1 O-ring
23		1 Adjustment pin	131	1	Piston S/A	■	173	1 Cover plug
24		1 C _v adjustment knob	133	2	Serial plate screw	■	180	1 Limit stop
25		1 C _v adjustment plate	134	1	Actuator spring	■	181	1 Locknut
26		2 Adjustment plate screw	135	1	Serial plate	■	182	1 Retaining ring (C _v max. <0.10)
27		4 Screw	○ 136	1	Diaphragm	■	183	1 Plug (C _v max. <0.10)
○	28	1 O-ring	137	1	Diaphragm cover	■	184	2 Pivot pin No. 2
○	29	1 O-ring	◆ 138	1	Union elbow t(incl. 138a)	■		
○	30	1 O-ring	139	1	Cover cap screw	■		

○ Recommended spare parts

□ Complete subassembly includes: plug and stem (183), retaining ring (182), seat ring (3e) and spacer (3f) (see Figure 2).

◆ Only for pneumatic positioner.

◎ See Figure 2.

◇ See table in Figure 23.

★ Only for handwheel (optional) (Figure 5).

○ Complete subassembly includes Ref. Nos. (155, 156 and 157).

■ Not shown.

▲ Only for cast bodies.

△ Only for optional limit-switch adaptation: quantity given for two limit switches (see Figure 13).

Sectional Drawing - Special Varilog

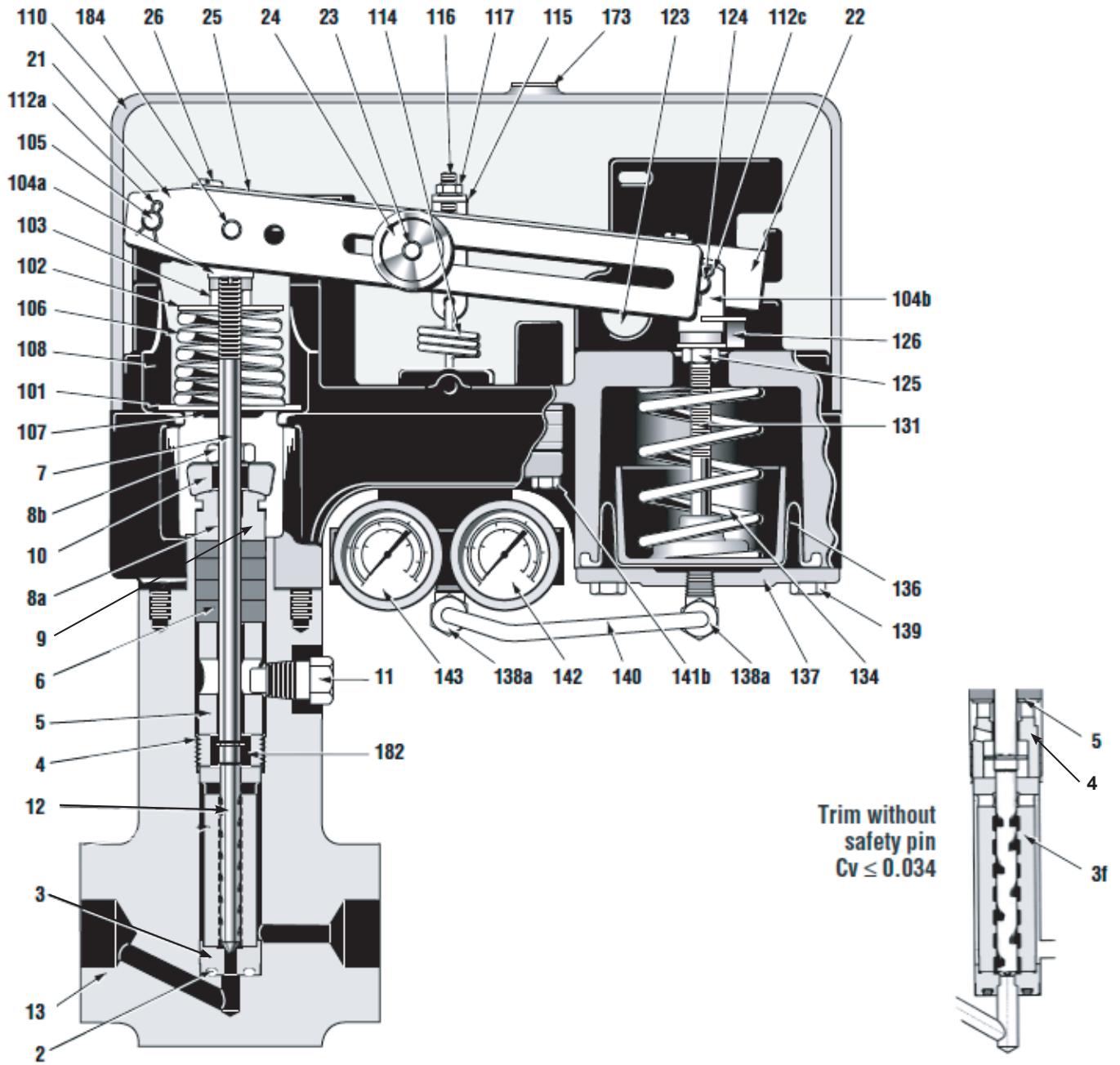

Special Varilog valve : feature on basis C_v

Characteristics

Valve Trim No.	Adjustable flow coefficient C_v (Critical discharge factor FL: greater than 0,98)							Spring scale		Max. supply	
	min.			max.				mbar	Psi	bar	
Special							0.007	414 - 1660	6 - 24	2.1	
Special							0.034	414 - 1660	6 - 24	2.1	
6	0.020	0.025		0.030	0.035	0.040	0.045	0.050	414 - 1660	6 - 24	2.1
5	0.04	0.05		0.06	0.07	0.08	0.09	0.10	414 - 1660	6 - 24	2.1
4	0.10	0.13		0.16	0.19	0.21	0.23	0.25	414 - 1660	6 - 24	2.1
3	0.25	0.30	0.35	0.40	0.45	0.50	0.55	0.60	414 - 1660	6 - 24	2.1

Maintenance

For all maintenance operations, use the Varipak valve C_v max. ≤ 0.10 value as a reference (Instruction Manual Ref. 30857).

Special feature on the basis of C_v

- **Varilog C_v max ≥ 0.60 :**

The valve plug is not fitted with a retaining ring, although a shoulder on the disk prevents it from passing through the part (5).

- **Varilog C_v max between 0.034 and 0.60:**

For these C_v , no difference with Varipak C_v max ≤ 0.10 .

- **Varilog $C_v \leq 0.034$:**

Disassembly:

Refer to paragraph 5.3 (DISASSEMBLY) in 28000 Series Varipak Manual Ref. 30857.

Disassembly procedure is common until point J. Then, particular steps apply for Varilog:

- K. Using an extracting tool, remove all of the packing rings (6) from the packing box. Remove the packing washer (5).
- L. Using a tube having a maximum OD of 21.3 mm and minimum ID of 9 mm with two diagonally opposite lugs at the end, loosen and remove the seat ring retainer (4) and the plug-stem assembly (12).

- M. Remove the liner (3f), the seat ring (3) and the seat ring gasket (2) using a hook made of approx. 3 mm wire. Carefully deburr the end of the hook.

Reassembly:

Refer to paragraph 5.4 (REASSEMBLY) in 28000 Series Varipak Manual Ref. 30857, replacing points A, B, C by the following:

- A. Fit a new seat ring gasket (2) into the trapezoidal groove of the seat ring (3) and install the trim [seat (3) + seat ring gasket (2), liner (3f), plug-stem assembly (12) + circlips (182)] into the valve body (13).

Note: The liner (3f), seat ring (3) and plug-stem assembly form a paired assembly. If one of these parts is damaged, all of the other parts must also be replaced. These parts are available in kit form, including the seat ring gasket (2) and circlips (182).

- B. Carefully apply Never Seez grease (or equivalent) on the threads and the bottom of the seat ring retainer (4). Using a tube having a maximum OD of 21.3 mm and minimum ID of 9 mm with two diagonally opposite lugs at the end, tighten the seat ring retainer (4) to 8 daN.m (59 ft-lb).
- C. Place the packing washer (5) on the seat ring retainer (4).

Note: Point D is not applicable for Varilog valves without safety pin. Go to point E to proceed further with Varilog reassembly.

Notes

Find the nearest local Channel Partner in your area:

valves.bakerhughes.com/contact-us

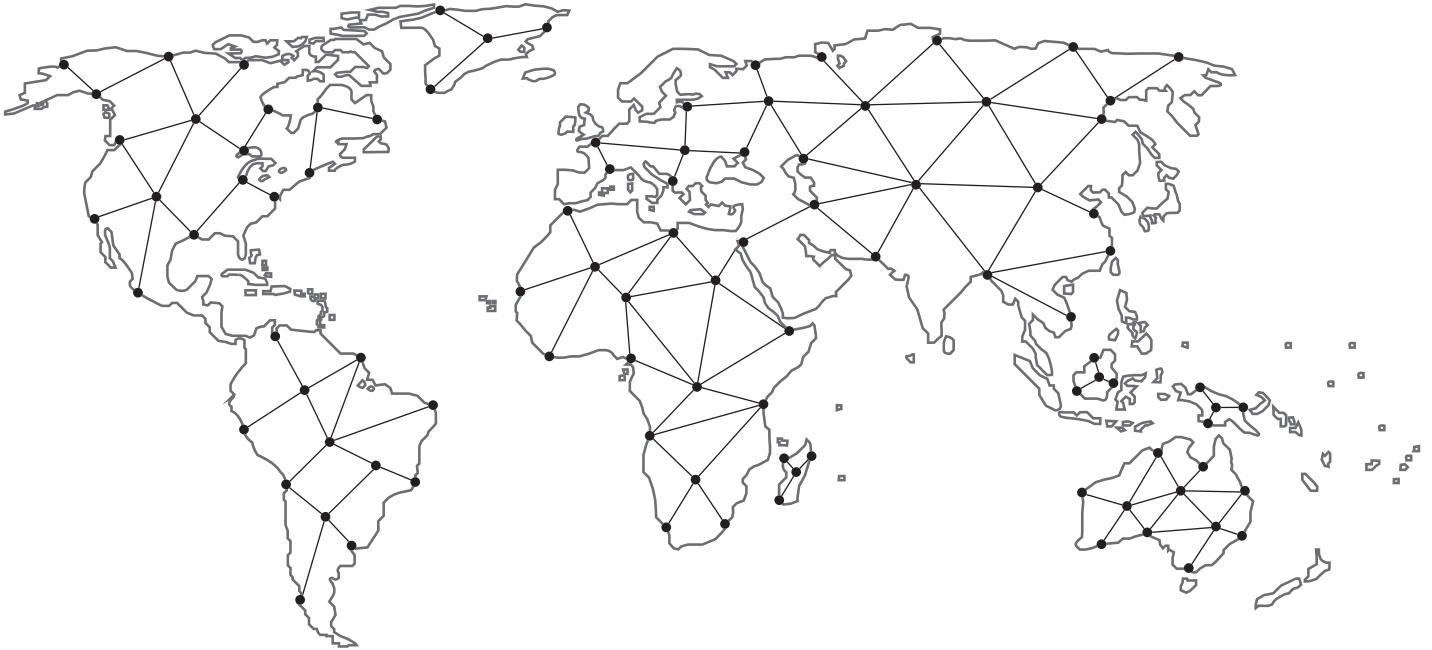

Tech Field Support & Warranty:

Phone: +1-866-827-5378

valvesupport@bakerhughes.com

valves.bakerhughes.com

Copyright 2021 Baker Hughes Company. All rights reserved. Baker Hughes provides this information on an "as is" basis for general information purposes. Baker Hughes does not make any representation as to the accuracy or completeness of the information and makes no warranties of any kind, specific, implied or oral, to the fullest extent permissible by law, including those of merchantability and fitness for a particular purpose or use. Baker Hughes hereby disclaims any and all liability for any direct, indirect, consequential or special damages, claims for lost profits, or third party claims arising from the use of the information, whether a claim is asserted in contract, tort, or otherwise. Baker Hughes reserves the right to make changes in specifications and features shown herein, or discontinue the product described at any time without notice or obligation. Contact your Baker Hughes representative for the most current information. The Baker Hughes logo, Masoneilan, VariPak and VariLog are trademarks of Baker Hughes Company. Other company names and product names used in this document are the registered trademarks or trademarks of their respective owners.

Baker Hughes 

bakerhughes.com