

12400 Series

Level Transmitter / Controller

ATEX Instruction Manual & Safety Guide (Rev. A-bis)

Advanced Level Measurement:

- SIL2-capable Liquid Level Transmitter
- Low and high level switch integrated functions
- Easy installation and simple operation
- Three built-in pushbuttons
- Seamless system integration



THESE INSTRUCTIONS PROVIDE THE CUSTOMER/OPERATOR WITH IMPORTANT PROJECT-SPECIFIC REFERENCE INFORMATION IN ADDITION TO THE CUSTOMER/OPERATOR'S NORMAL OPERATION AND MAINTENANCE PROCEDURES. SINCE OPERATION AND MAINTENANCE PHILOSOPHIES VARY, BAKER HUGHES COMPANY (AND ITS SUBSIDIARIES AND AFFILIATES) DOES NOT ATTEMPT TO DICTATE SPECIFIC PROCEDURES, BUT TO PROVIDE BASIC LIMITATIONS AND REQUIREMENTS CREATED BY THE TYPE OF EQUIPMENT PROVIDED.

THESE INSTRUCTIONS ASSUME THAT OPERATORS ALREADY HAVE A GENERAL UNDERSTANDING OF THE REQUIREMENTS FOR SAFE OPERATION OF MECHANICAL AND ELECTRICAL EQUIPMENT IN POTENTIALLY HAZARDOUS ENVIRONMENTS. THEREFORE, THESE INSTRUCTIONS SHOULD BE INTERPRETED AND APPLIED IN CONJUNCTION WITH THE SAFETY RULES AND REGULATIONS APPLICABLE AT THE SITE AND THE PARTICULAR REQUIREMENTS FOR OPERATION OF OTHER EQUIPMENT AT THE SITE.

THESE INSTRUCTIONS DO NOT PURPORT TO COVER ALL DETAILS OR VARIATIONS IN EQUIPMENT NOR TO PROVIDE FOR EVERY POSSIBLE CONTINGENCY TO BE MET IN CONNECTION WITH INSTALLATION, OPERATION OR MAINTENANCE. SHOULD FURTHER INFORMATION BE DESIRED OR SHOULD PARTICULAR PROBLEMS ARISE WHICH ARE NOT COVERED SUFFICIENTLY FOR THE CUSTOMER/OPERATOR'S PURPOSES THE MATTER SHOULD BE REFERRED TO BAKER HUGHES.

THE RIGHTS, OBLIGATIONS AND LIABILITIES OF BAKER HUGHES AND THE CUSTOMER/OPERATOR ARE STRICTLY LIMITED TO THOSE EXPRESSLY PROVIDED IN THE CONTRACT RELATING TO THE SUPPLY OF THE EQUIPMENT. NO ADDITIONAL REPRESENTATIONS OR WARRANTIES BY BAKER HUGHES REGARDING THE EQUIPMENT OR ITS USE ARE GIVEN OR IMPLIED BY THE ISSUE OF THESE INSTRUCTIONS.

THESE INSTRUCTIONS ARE FURNISHED TO THE CUSTOMER/OPERATOR SOLELY TO ASSIST IN THE INSTALLATION, TESTING, OPERATION, AND/OR MAINTENANCE OF THE EQUIPMENT DESCRIBED. THIS DOCUMENT SHALL NOT BE REPRODUCED IN WHOLE OR IN PART WITHOUT THE WRITTEN APPROVAL OF BAKER HUGHES.

INDEX

Warning	1
1. Level Transmitter/Controller Type 12400 Operation	2
2. Type 12400 Numbering System	2
3. Technical Specifications	3
3.1 Performances.....	3
3.2 Schematics and Parts Identification	3
4. ATEX Intrinsic Safety Marking for Type 12400	4
5. ATEX Flameproof Marking for Type 12400	4
6. Electrical Connections and Conduit Entry	4
6.1 Voltage Supply Allowable	4
6.2 Maximum Power	4
6.3 Output Current and Loop Resistor	4
6.4 Intrinsic Safety Entity Parameters	5
6.5 Conduit Entry in Flameproof Application	5
7. Assembly and Installation	5
7.1 Assembly.....	5
7.2 12400 Flameproof Installation.....	5
7.3 12400 Intrinsic Safety and Type n Installation.....	5
8. Setup and Start Up	6
8.1 Coupling.....	6
8.2 Configuration.....	6
8.3 Calibration	6
8.4 Start up.....	6
9. Maintenance and Service	6
9.1 General Rules	6
9.2 Before Maintenance Activity	6
9.3 During Maintenance Activity.....	6
9.4 After Maintenance Activity	6
10. Special Conditions of Use	7
10.1 For Intrinsic Safety and Flameproof	7
10.2 For Intrinsic Safety	7
10.3 For Flameproof.....	7
Annex I	9
Annex II	10

WARNING

BEFORE installing, using or carrying out any maintenance tasks associated with this instrument, READ THE INSTRUCTIONS CAREFULLY.

The 12400 Series complies with the essential safety requirements of the European Directive ATEX 2014/34/EU. It is certified to be used in Gas or Dust explosive atmospheres, groups IIA, IIB, IIC and IIIC:

- Category II 1GD – zones 0, 1, 2, 20, 21 and 22 for the protection mode “ia”
- Category II 2GD – zones 1, 2, 21 and 22 for the protection mode “db” and “tb”

They also comply with the essential safety requirements of the European Directive EMC 2014/30/EU as amended, for use within an industrial environment.

Products certified as **explosion proof equipment MUST BE:**

- a. Installed, put into service, used and maintained in compliance with European and/or national and local regulations and in accordance with the recommendations contained in the relevant standards concerning potentially explosive atmospheres.
- b. Used only in situations those comply with the certification conditions shown in this document and after verification of their compatibility with the zone of intended use and the permitted maximum ambient temperature.
- c. Installed, put into service and maintained by qualified and competent professionals who have undergone suitable training for instrumentation used in areas with potentially explosive atmosphere. Such trainings are not supported by Baker Hughes.

It is the end user's responsibility to:

- **Verify material compatibility with the application**
- **Ensure proper use of fall protection when working at heights, per Safe Site Work Practices**
- **Ensure use of proper Personal Protective Equipment**
- **Take the appropriate actions to ensure that site personnel who are performing installation, commissioning and maintenance have been trained in proper site procedures for working with and around equipment, per Safe Site Work Practices**

Baker Hughes reserves the right to discontinue manufacture of any product or change product materials, design, or specifications without notice.

Under certain operating conditions, the use of damaged instruments could cause a degradation of the performances of the system which may lead to personal injury or death.

Use only genuine replacement parts, which are provided by the manufacturer to guarantee that the products comply with the essential safety requirements of the European Directives mentioned above.

1. Level Transmitter/Controller Type 12400 Operation

To be operational, the digital level and controller type 12400 must be mounted on a torque tube and on a displacer chamber equipped with the displacer.

Any change in the level of liquid or the interface between two liquids will change the apparent weight of the displacer and cause a change of the angle of rotation in the torque tube.

This angle is measured by a sensor and converted by an electronic module:

- Either to a standardized 4-20mA current, proportional with the change in level, when configured as a **level transmitter**,
- Or, to a 4-20mA current, generated by a PID algorithm derived from the error between the actual level of liquid and the local set point, when configured as a **level controller**.

2. Type 12400 Numbering System

12	4	a	b	c	d
Model	Action	Mounting	Protection	Housing Material	
4 - HART communication protocol, LCD display and push buttons, SIL certified	1 – Controller with adjustable switches and second 4-20 mA analogue output signal: AO_1, AO_2, DO_1, DO_2 2 – Transmitter: AO_1 3 – Transmitter with adjustable switches and second 4-20 mA analogue output signal: AO_1, AO_2, DO_1, DO_2	0 – Top and bottom, Screwed, BW or SW 1 – Top and bottom, Flanged 2 – Side and side, Flanged 3 – Top vessel, Flanged 4 – Side vessel, Flanged 5 – Top and side, Screwed, BW or SW 6 – Side and bottom, Screwed, BW or SW 7 – Side and bottom, Flanged 8 – Top and side, Flanged 9 – Side and side, Screwed, BW or SW	1 – FM & FMc SI, NI, DIP, XP and Nema 4X-6P 2 – JIS , Xproof 3 – CU TR , IS, Xproof and IP 66/67 4 – INMETRO , IS, Xproof 5 – ATEX & IECEx IS, Xproof, and IP 66/67 6 – Other approvals (based on ATEX / IECEx) 7 – Other approvals (not based on ATEX / IECEx)	1 – Aluminum with epoxy painting 2 – Stainless steel	

Note: only the Transmitter function is SIL certified.

3. Technical Specifications

3.1 Performances

Refer to specific gravities between 0.15 and 1.4 with a standard displacer 907 cm³ @ 1362 g.

- Accuracy: ± 0.5 %
- Hysteresis: ± 0.3 %
- Repeatability: ± 0.2 %
- Dead zone: ± 0.1 %
- Ambient temperature ranges:
 - In operation: -50°C to +80°C
 - Storage and transport: -50°C to +93°C
- Water ingress protection: IP66/67

3.2 Schematics & Parts Identification

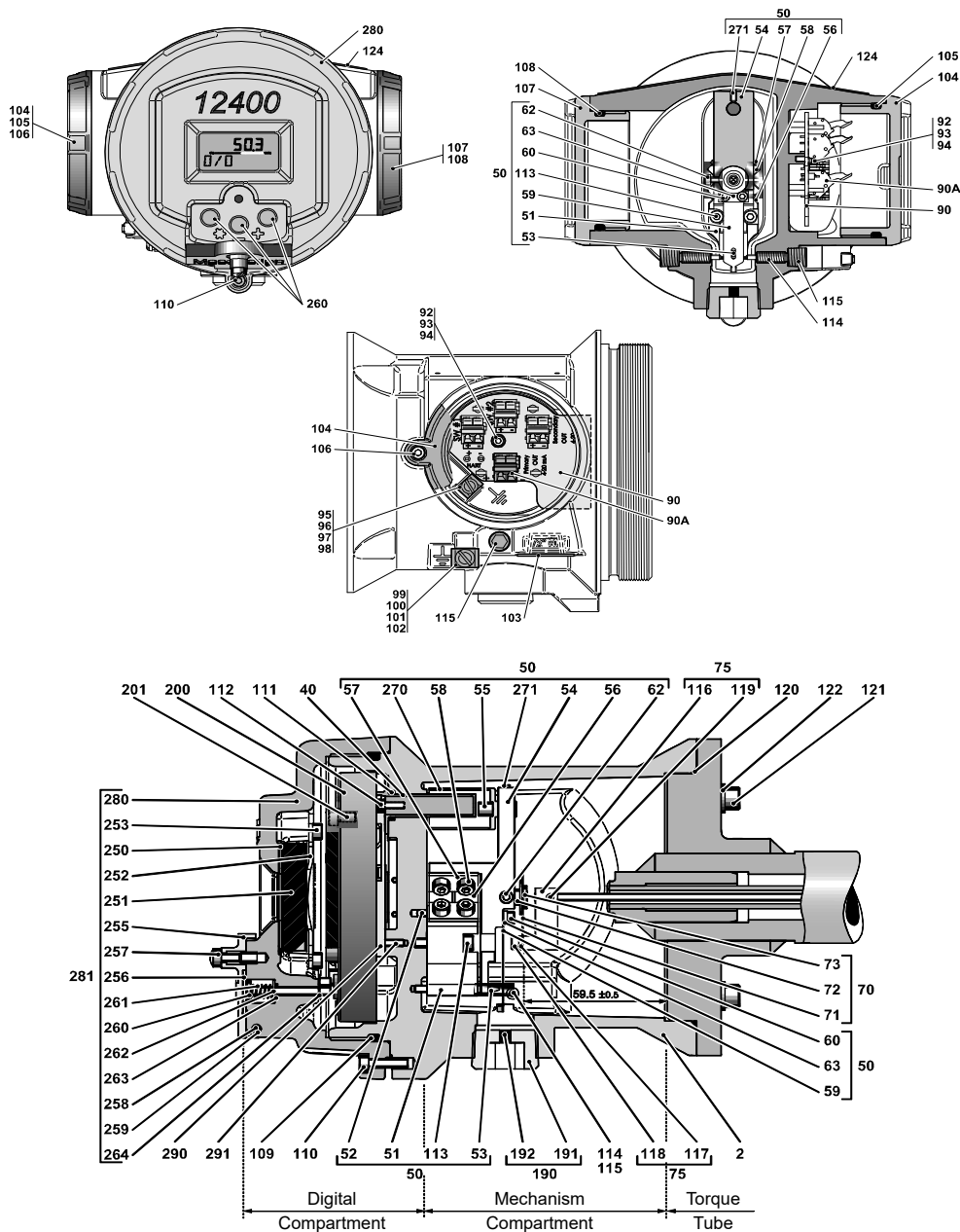

4. ATEX Intrinsic Safety Marking for Type 12400

The marking is on the serial plate stamped on the 12400 housing (*rep 124*).

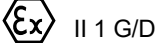
- Name and address of the manufacturer:
Dresser Produits Industriels S.A.S.
14110 CONDE SUR NOIREAU - FRANCE
- Type designation: 12400
See numbering system for complete codification §2.
- Basic marking:
 II 1 G/D
- Complementary marking:
 - Ex ia IIC T6 Ga Ta -40°C, +55°C
Ex ia IIIC T85°C Da Ta -40°C, +55°C
 - Ex ia IIC T5 Ga Ta -40°C, +70°C
Ex ia IIIC T100°C Da Ta -40°C, +70°C
 - Ex ia IIC T4 Ga Ta -40°C, +80°C
Ex ia IIIC T135°C Da Ta -40°C, +80°C
- Serial number
- Year of manufacturing
- CE ••• Number of notified body
- EU-Type Examination Certificate and IECEx Certificate of Conformity
- WARNING:**
"POTENTIAL DANGER OF ELECTROSTATIC CHARGES. SEE INSTRUCTIONS"

5. ATEX Flameproof Marking for Type 12400

The marking is on the serial plate stamped on the 12400 housing (*rep 124*).

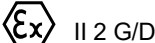
- Name and address of the manufacturer:
Dresser Produits Industriels S.A.S.
14110 CONDE SUR NOIREAU - FRANCE
- Type designation: 12400
See numbering system for complete codification §2.
- Basic marking:
 II 2 G/D
- Complementary marking:
 - Ex db IIC T6 Gb -50°C < Tamb < +75°C
Ex tb IIIC T85°C Db IP66/IP67 -50°C < Tamb < +75°C
 - Ex db IIC T5 Gb -50°C < Tamb < +80°C
Ex tb IIIC T100°C Db IP66/IP67 -50°C < Tamb < +80°C
 - Ex db IIC T4 Gb -50°C < Tamb < +80°C
Ex tb IIIC T135°C Db IP66/IP67 -50°C < Tamb < +80°C
- Serial number
- Year of manufacturing
- CE ••• Number of notified body

- EU-Type Examination Certificate and IECEx Certificate of Conformity
- WARNING:**
"DO NOT OPEN IF AN EXPLOSIVE ATMOSPHERE MAY BE PRESENT"
"POTENTIAL DANGER OF ELECTROSTATIC CHARGES. SEE INSTRUCTIONS"
- Cable temperature: must be mentioned if the ambient temperature is greater than 70°C:

Ambient Temperature	Cable Temperature
75°C	80°C
80°C	85°C

6. Electrical Connections and Conduit Entry

The type 12400 must be installed and put into service in conformance with **EN/IEC 60079-14** and / or national and local regulations applicable for explosive atmospheres.

6.1 Voltage supply allowable

Connect the wires to the instrument's terminals, taking care of complying with polarities + and - and maximum voltage allowed mentioned in the table below. Make the earth connections with the internal and external ground terminals.

Voltage Supply U (V)	AO_1		AO_2		DO_1/DO_2	
	MINI	MAXI	MINI	MAXI	MINI	MAXI
Flameproof	10V	40V	10V	30V	0.5V	30V
Intrinsic Safety	10V	30V	10V	30V	0.5V	30V

6.2 Maximum Power

3 W inside the 12400 housing.

6.3 Output Current and Loop Resistor

- AO_1 et AO_2:**
3.8 mA to 20.5 mA for measurement
< 3.6 mA or > 21 mA in case of fault
- Maximum loop resistor**
For AO_1 et AO_2 : $R_{maxi} (\Omega) = \frac{U (V) - 10 (V)}{I_{max} (A)}$

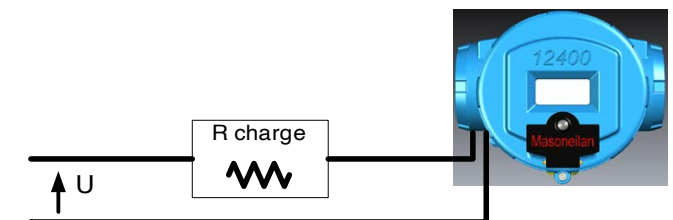

- DO_1 et DO_2**
Open collector output. Maximum current is 1A. A load resistor must be inserted in the loop to limit the current to this maximum.

6.4 Intrinsic Safety Entity Parameters

AO_1: terminal identification: *Primary OUT 4- 20 mA*

Max. Input Voltage	Ui	30	V
Max. Input Current	Ii	125	mA
Max. Input Power	Pi	900	mW
Max. Internal Capacitance	Ci	2.0	nF
Max. Internal Inductivity	Li	500	µH

AO_2: terminal identification: *Secondary OUT 4- 20 mA*

Max. Input Voltage	Ui	30	V
Max. Input Current	Ii	125	mA
Max. Input Power	Pi	900	mW
Max. Internal Capacitance	Ci	9.0	nF
Max. Internal Inductivity	Li	500	µH

DO_1, DO_2: terminal identification: *SW #1 and SW #2*

Max. Input Voltage	Ui	30	V
Max. Input Current	Ii	125	mA
Max. Input Power	Pi	900	mW
Max. Internal Capacitance	Ci	4,5	nF
Max. Internal Inductivity	Li	10	µH

6.5 Conduit entry in flameproof application

The connections can be done with different variations taking into account approved manufacturer and requested approvals:

- A cable entry of a certified type *Ex d IIC / Ex tb IIIC* can be mounted directly on the single ½" NPT (ANSI/ASME B1.20.1) housing conduit connection.
- Adaptor or reducer if apparatus certified ATEX or IECEx (type Copper CAPRI CODEC)
- For multiple cable entries (3 maximum), the adaptor **Y237** "Masoneilan" can be used for ATEX application only.
 - If one **Y237** input is not used, the conduit will be closed by a plug if apparatus certified ATEX or IECEx (type Copper CAPRI CODEC)
 - If two **Y237** inputs are not used, the **Y237** must be suppressed.
- The cable entry with or without its adaptor/reducer and the Y237 with its cable entry must be installed in conformance with **ANNEX I**.

7. Assembly and Installation

7.1 Assembly

The 12400 must be first mounted onto a torque tube, a mechanism chamber et depending the type with a displacer chamber.

- Refer to the 12400 Instruction and Operation Manual **IOM GEA19367** manual for further details.
- Take into account all special conditions of used listed in §10.

7.2 12400 Flameproof Installation

The 12400 may be installed in gas and dust explosive atmospheres of groups IIA, IIB, IIC and IIIC, category II 2GD for zones 1, 2, 21 and 22 with "db" and "tb" protection mode.

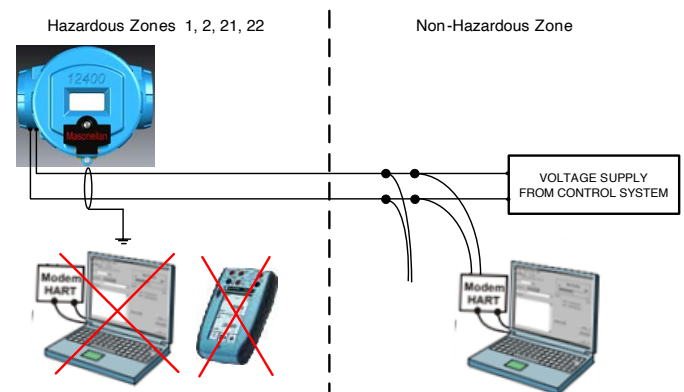

7.3 12400 Intrinsic Safety and Type n Installation

The 12400 may be installed in gas and dust explosive atmospheres of groups IIA, IIB, IIC and IIIC, category II 1GD for zones 0, 1, 2, 20, 21 and 22 with "ia" protection mode.

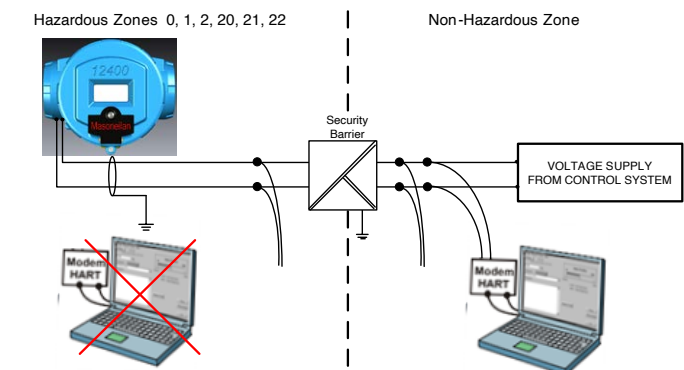

Note:

- *It is under the user responsibility to check the installation against Intrinsic safety rules taking into account entity parameters of all devices in the loop in addition of temporary one like PC or HART communicator, measurement devices, etc.*
- *The HART communicator must be approved for Intrinsic Safety application. Read its instruction manual and apply the device serial plate marking.*

8. Set Up and Start Up

- These operations must be done in conformance with **EN/IEC 60079-17** and / or national and local regulations applicable for explosive atmospheres.
- Before carrying out any work on the device, check the local conditions are free of potentially explosive atmosphere for safe opening of the covers.
- The Push Buttons (**rep 260**) can be used for SETUP operations in zones 0, 1 and 2.
- For using HART communication tools, please be under the requirements defined in **§10**.
- During SETUP operations, the 12400 is no longer in NORMAL operation. The analog outputs signals coming from AO_1, AO_2, DO_1 and DO_2 could be not in accordance with the process monitoring.

The following coupling, configuration or calibration operations are only necessary when they have not already been carried out by the manufacturer or by the end user. In all cases, check that the operations comply with the instrument's intended use.

- Refer to **ANNEX II** for the pushbutton menu flowchart.
- Please refer to the 12400 Instruction and Operation Manual **IOM GEA19367** to complete the following actions.

8.1 Coupling

The coupling operation must be carried out before configuration and calibration. It consists of correctly positioning the sensor onto the torque tube.

8.2 Configuration

This operation must be carried out before the calibration done and defined the working of the 12400. The main parameters are:

- Transmitter type:..... level or interface
- Mounting: left or right
- Current action for AO_1 and AO_2:..... direct or reverse

8.3 Calibration

This operation requests to simulate or to change the level of liquid or the interface between two liquids. The basic operations can be resuming by:

- Recording of specific gravities of calibration and service.
- ZERO (Low level) and the SPAN (High level) calibration.

8.4 Start Up

Before to power up the digital level transmitter and controller type 12400, check that:

- The 12400 is in **NORMAL** mode.
- The covers are fully screwed (**rep 104, 107, 255 and 280**) and the security cover screws are well locked (**rep 106, 110 and 257**).

9. Maintenance and Service

9.1 General Rules

These operations must be put into service in conformance with **EN/IEC 60079-17** and / or national and local regulations applicable for explosive atmospheres.

9.2 Before Maintenance Activity

Before carrying out any work on the device, check the local conditions are free of potentially explosive atmosphere for safe opening of the covers.

9.3 During Maintenance Activity

- Take into account all special conditions of use listed **§10**.
- Pay particular attention to the following points:
 - Check that no part of the type 12400 is damaged. In the event of damage, replace the defective parts with genuine manufacturer's replacement parts only.
 - Check that the pressure limiting plug at the back of the mechanism compartment (**rep 190**) and its spongy gasket (**rep 192**) are presents without any damage.
 - Check the main cover seal (**rep 109**), the terminal compartment seal (**rep 105**) and the mechanism compartment seal (**rep 108**) are free of any damage.
 - Check the 12400 housing and the magnet assembly (**rep 50**) inside the mechanism compartment are free of any damage.
 - Check the gland and the electrical connections.
 - To proceed to a cleaning of the different sides of the enclosure to avoid the deposits of dusts for instruments working in zones 20, 21 and 22.

9.4 After Maintenance Activity

After doing any work on the device, check the covers are fully screwed (**rep 104, 107, 255 and 280**) and the security cover screws are well locked (**rep 106, 110 and 257**).

10. Special Conditions of Use

10.1 For Intrinsic Safety and Flameproof

- It is under the user responsibility to check once a year the gasket and in the event of damage to replace the defective parts with manufacturer's replacement parts only.
- The user will have to check the temperature increase on the 12400 head coming from the mechanical part in contact with the 12400 housing or through the process thermal radiation be less or equal than the temperature classification allowed. This must be done in conformance with **EN/IEC 60079-14** and / or national and local regulations applicable for explosive atmospheres.
- For use in dusty hazardous areas (zones 20, 21 & 22), the user will have to clean regularly the different sides of the enclosure to avoid the deposits of dusts; the maximum thickness must be <5 mm. This cleaning will be done with respect to the next requirement.
It is recommended for safe operation, the local conditions around the device are free of potentially explosive atmosphere.
- To avoid the risk of ignition from electrostatic discharge it shall be necessary to follow the guidance of **IEC/TS 60079-32-1** for example to clean the device with a wet rag.
It is recommended for safe operation, the local conditions around the device are free of potentially explosive atmosphere.
- The final user during the 12400 installation on site must indicate the protection mode used on the serial plate by removing the tear-off tabs or putting a cross in the dedicated area as per **EN/IEC 60079-0** requirements.

ONE OF THESE IDENTIFICATION MODES FOR END USERS

N° SERIE SERIAL NBR 007227 TYPE MODEL 12420-51
 N° ARTICLE PART NBR 400149855-999

AVERTISSEMENT: DANGER POTENTIEL DE CHARGES ELECTROSTATIQUES. VOIR INSTRUCTIONS
WARNING: POTENTIAL DANGER OF ELECTROSTATICS CHARGES. SEE INSTRUCTIONS.

INERIS 09ATEX0058X IECEx INE 09.0005X
Ex II 2 G D

Complementary Gas Flameproof Marking Ex d IIC T° Gb
 Complementary Dust Flameproof Marking Ex tb IIIC T°°C Db

Umax: AO_1 = 40V Umax: AO_2, DO_1, DO_2 = 30V
AVERTISSEMENT: NE PAS OUVRIR SI UNE ATMOSPHERE EXPLOSIVE PEUT ÊTRE PRÉSENTE
WARNING: DO NOT OPEN IF AN EXPLOSIVE ATMOSPHERE MAY BE PRESENT

INERIS 09ATEX0073X IECEx INE 09.0022X
Ex II 1 G D

Complementary Gas Intrinsic Safety Marking Ex ia IIC T° Ga
 Complementary Dust Intrinsic Safety Marking Ex ia IIIC T°°C Da

Waterproof Marking IPxx/xx

CE 0080 ANNEE YEAR 2012
Dresser Produits Industriels S.A.S.
14110 CONDE SUR NOIREAU - FRANCE

Printable areas for protection mode used:

Removable areas for protection mode used: [indicated by arrows on the left side of the plate]

10.2 For Intrinsic Safety

- The cable entry must have a protection level at least equal to IP6X according to **EN/IEC 60529** standards.
- For the 12400 housing with aluminium material, the user will have to determine the use of the device for group II category 1 (zone 0) against potential inflammable source causing by sparks in the event of impact or friction.
- The voltage supply connected on each 12400 connectors must be certified for use in group IIC and the loop intrinsic safety approved. The entity parameters of the voltage supply must be compatible with the entity parameters of the 12400 described **§6.4**.

10.3 For Flameproof

- For ambient temperature greater than 70°C, the user must choose a cable entry and a cable compatible with:

Ambient Temperature	Cable Temperature
75°C	80°C
80°C	85°C

- The cable entry and the cable must be compatible with the minimum temperature of -50°C indicated on the marking plate.
- The cable entry must have a protection level at least equal to IP66/67.
- The width of the flameproof joints is superior to the values specified in the tables of the standard **EN/IEC 60079-1**.
The flameproof joints are not intended to be repaired.
- The joints of:

Joints	Rep
Three buttons axis	260
Three covers thread	104, 107, 280
O-rings	105, 108, 109

are greased with the following greases:

Grease Type	Manufacturer
GRAPHENE 702	ORAPI
MOLYKOTE 111 COMPOUND	MOLYKOTE®
MULTILUB	MOLYKOTE®
GRIPCOTT NF	MOLYDAL

This page intentionally left blank.

Annex I

Cable Gland Accessories Mounting on ATEX and IECEx Instruments

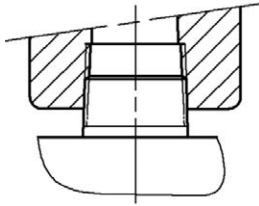
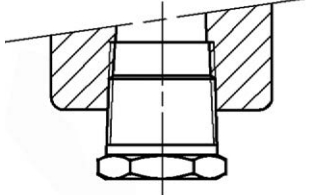
	
With Cable Entry Certified Ex d IIC , Ex tb IIIC	with Adaptor or Reducer Certified Ex d IIC , Ex tb IIIC
Taper threaded joints in conformance with ANSI ASME B1.20.1: 5 threads provided on each part	Taper threaded joints in conformance with ANSI ASME B1.20.1: 5 threads provided on each part Cemented with "Loctite Freinfilet Fort" or equivalent product with similar efficiency

Y237 Adaptor Cable Gland Accessories Mounting on ATEX Instruments Only

CABLE ENTRY

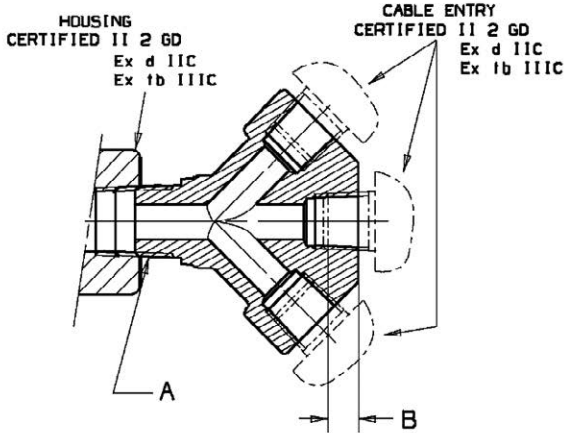

ADAPTOR or REDUCER

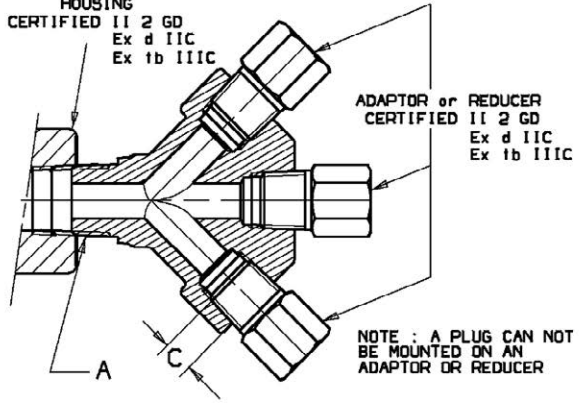

PLUG

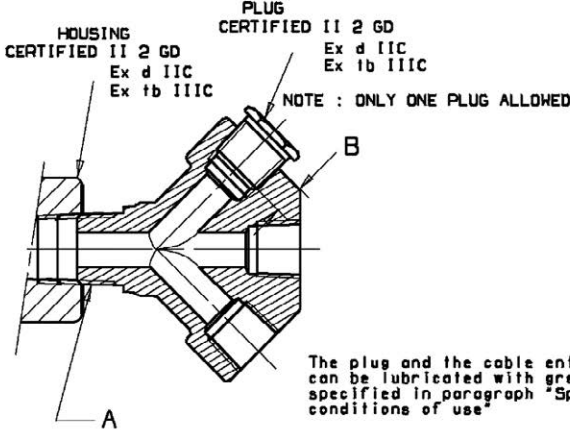

The plug and the cable entries can be lubricated with greases specified in paragraph "Special conditions of use"

A: Taper threaded joints in conformance with ANSI ASME B1.20.1:
 5 threads provided on each part
 Cemented with "LOCTITE FREINFILET FORT" or equivalent product with similar efficiency

B: Taper threaded joints in conformance with ANSI ASME B1.20.1:
 5 threads provided on each part
 Cylindrical thread joints in conformance with ISO 965-1/3
 Effective threads engaged ≥ 5
 Depth of engagement ≥ 8 mm

C: Taper threaded joints in conformance with ANSI ASME B1.20.1:
 5 threads provided on each part
 Cylindrical thread joints in conformance with ISO 965-1/3
 Effective threads engaged ≥ 5
 Depth of engagement ≥ 8 mm
 Cemented with "LOCTITE FREINFILET FORT" or equivalent product with similar efficiency

Annex II

Menus of Transmitter models (12420 and 12430)

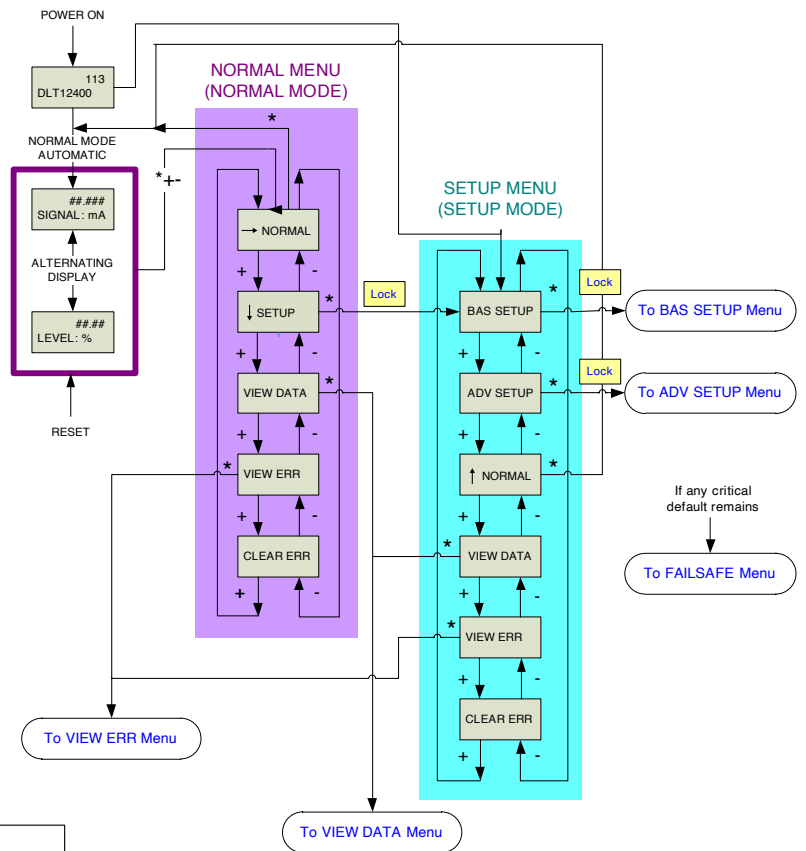

Menus of Controller model (12410)

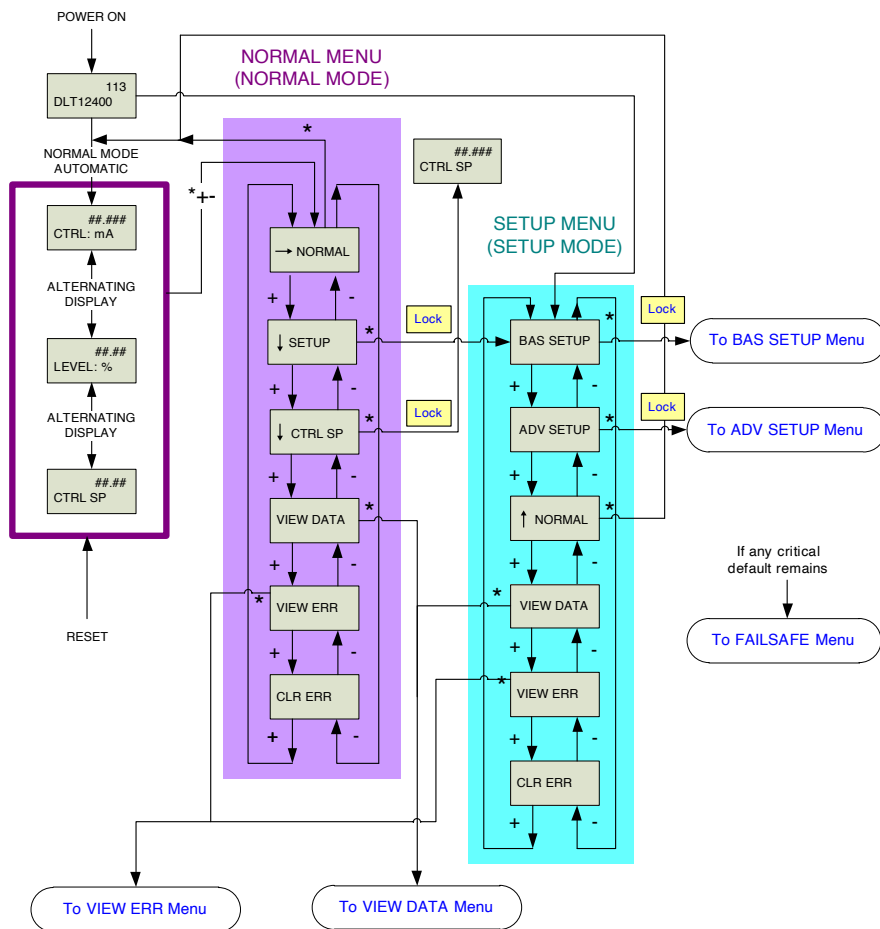

Notes

Notes

Find the nearest local Channel Partner in your area:

valves.bakerhughes.com/contact-us

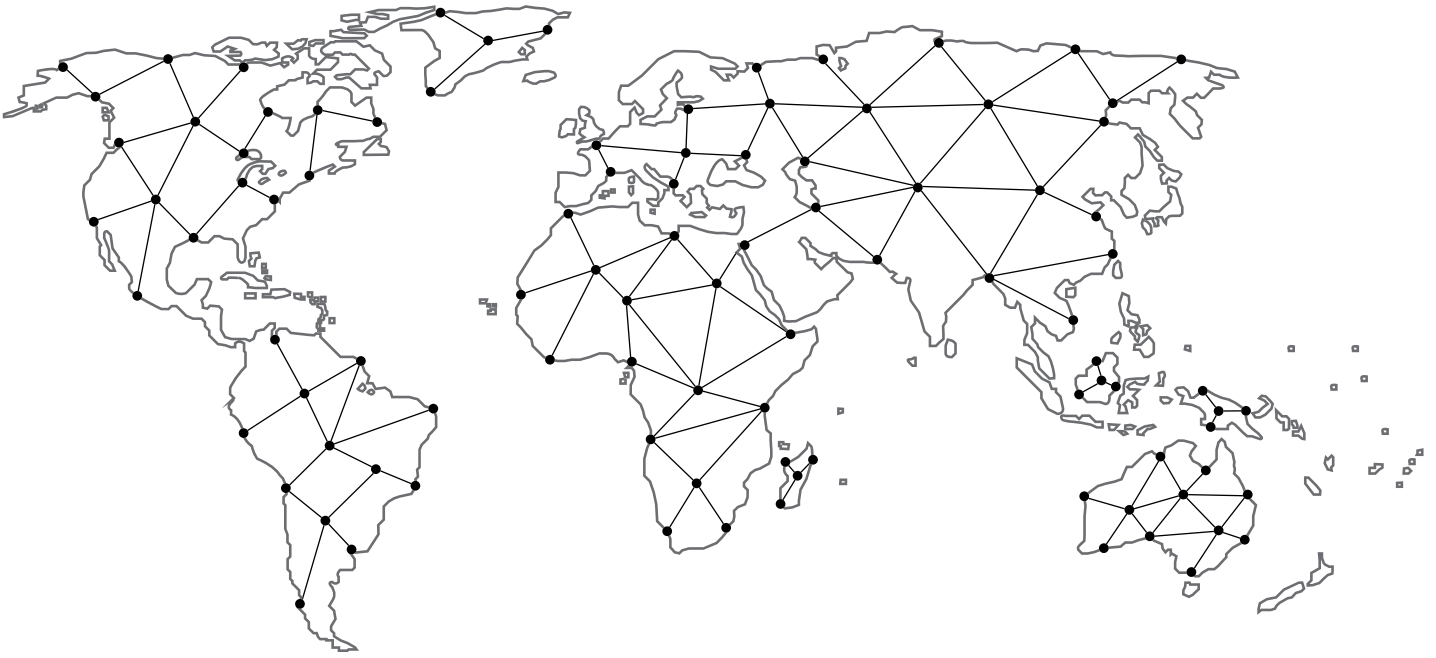

Tech Field Support & Warranty:

Phone: +1-866-827-5378

valvesupport@bakerhughes.com

valves.bakerhughes.com

Copyright 2019 Baker Hughes Company. All rights reserved. Baker Hughes provides this information on an "as is" basis for general information purposes. Baker Hughes does not make any representation as to the accuracy or completeness of the information and makes no warranties of any kind, specific, implied or oral, to the fullest extent permissible by law, including those of merchantability and fitness for a particular purpose or use. Baker Hughes hereby disclaims any and all liability for any direct, indirect, consequential or special damages, claims for lost profits, or third party claims arising from the use of the information, whether a claim is asserted in contract, tort, or otherwise. Baker Hughes reserves the right to make changes in specifications and features shown herein, or discontinue the product described at any time without notice or obligation. Contact your Baker Hughes representative for the most current information. The Baker Hughes logo and Masoneilan are trademarks of Baker Hughes Company. Other company names and product names used in this document are the registered trademarks or trademarks of their respective owners.

Baker Hughes 