

# DigitalFlow™ GF868

Ultrasonic Flowmeter for Flare Gas  
Startup Guide (1 and 2-Channel)





# DigitalFlow™ GF868

## *Ultrasonic Flowmeter for Flare Gas*

### Startup Guide (1 and 2-Channel)

BH015C33 Rev. F  
Jul 2021

[panametrics.com](http://panametrics.com)

Copyright 2021 Baker Hughes company.

This material contains one or more registered trademarks of Baker Hughes Company and its subsidiaries in one or more countries. All third-party product and company names are trademarks of their respective holders.

[no content intended for this page]

---

## Information Paragraphs

*Note:* These paragraphs provide information that provides a deeper understanding of the situation, but is not essential to the proper completion of the instructions.

**IMPORTANT:** These paragraphs provide information emphasizing instructions which are essential to proper setup of the equipment. Failure to follow these instructions carefully may cause unreliable performance.



**WARNING!** Indicates a potentially hazardous situation which can result in serious personal injury or death, if it is not avoided.



**CAUTION!** Indicates a potentially hazardous situation which can result in minor or moderate injury to personnel or damage to the equipment, if it is not avoided.



**HIGH VOLTAGE!** This symbol indicates the presence of high voltage. It calls your attention to situations or operations that could be dangerous to you and other persons operating the equipment. Read these messages and follow the instructions carefully.

## Safety Issues



**WARNING!** It is the responsibility of the user to make sure all local, county, state and national codes, regulations, rules and laws related to safety and safe operating conditions are met for each installation.

## Auxiliary Equipment

### Local Safety Standards

The user must make sure that he operates all auxiliary equipment in accordance with local codes, standards, regulations, or laws applicable to safety.

### Working Area



**WARNING!** Auxiliary equipment may have both manual and automatic modes of operation. As equipment can move suddenly and without warning, do not enter the work cell of this equipment during automatic operation, and do not enter the work envelope of this equipment during manual operation. If you do, serious injury can result.



**WARNING!** Make sure that power to the auxiliary equipment is turned OFF and locked out before you perform maintenance procedures on the equipment.

## Qualification of Personnel

Make sure that all personnel have manufacturer-approved training applicable to the auxiliary equipment.

## Personal Safety Equipment

Make sure that operators and maintenance personnel have all safety equipment applicable to the auxiliary equipment. Examples include safety glasses, protective headgear, safety shoes, etc.

## Unauthorized Operation

Make sure that unauthorized personnel cannot gain access to the operation of the equipment.

## Environmental Compliance

### Waste Electrical and Electronic Equipment (WEEE) Directive

Panametrics is an active participant in Europe's *Waste Electrical and Electronic Equipment (WEEE)* take-back initiative, directive 2012/19/EU.

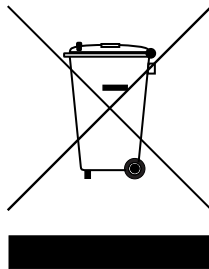

The equipment that you bought has required the extraction and use of natural resources for its production. It may contain hazardous substances that could impact health and the environment.

In order to avoid the dissemination of those substances in our environment and to diminish the pressure on the natural resources, we encourage you to use the appropriate take-back systems. Those systems will reuse or recycle most of the materials of your end life equipment in a sound way.

The crossed-out wheeled bin symbol invites you to use those systems.

If you need more information on the collection, reuse and recycling systems, please contact your local or regional waste administration.

Visit [www.bakerhughesds.com/health-safetyand-environment-hse](http://www.bakerhughesds.com/health-safetyand-environment-hse) for take-back instructions and more information about this initiative.

## Chapter 1. Installation

1.1	Introduction	1
1.2	Unpacking	1
1.3	Site Considerations	2
1.3.1	Electronics Console Location	2
1.3.2	Flowcell Location	2
1.3.3	Transducer Locations	2
1.3.4	Cable Lengths	2
1.3.5	Temperature and Pressure Transmitters	3
1.3.6	Transducer Cables	3
1.4	Installing a Flowcell	3
1.5	Installing Temperature and Pressure Transmitters	5
1.6	Mounting the GF868 Enclosure	5
1.7	Making Electrical Connections	6
1.7.1	Wiring the Line Power	6
1.7.2	Wiring the Transducers	8
1.7.3	Wiring the 0/4-20 mA Analog Outputs	8
1.7.4	Wiring the Serial Port	8
1.7.5	Wiring an Alarms Option Card	13
1.7.6	Wiring a 0/4-20 mA Analog Inputs Option Card	14
1.7.7	Wiring the Totalizer/ Frequency Outputs	15
1.7.8	Wiring the RTD Inputs	15

## Chapter 2. Initial Setup

2.1	Introduction	21
2.2	Navigating Through the User Program	21
2.3	Accessing the User Program	22
2.3.1	1-Channel Meter	22
2.3.2	2-Channel Meter	22
2.4	Activating a Channel	23
2.4.1	1-Channel Meter	23
2.4.2	2-Channel Meter	23
2.4.3	1 and 2-Channel Meters	23
2.5	Entering System Data for a Channel	24
2.5.1	A 1-Channel Meter	24
2.5.2	A 2-Channel Meter	25
2.5.3	1 and 2-Channel Meters	25
2.6	Entering Pipe Data	27
2.6.1	Transducer Number	27
2.6.2	Pipe OD	27
2.6.3	Pipe Wall	28
2.6.4	Path Length	28
2.6.5	Axial Length	28
2.6.6	Reynolds Correction	28

## Chapter 3. Operation

3.1	Introduction	31
3.2	Powering Up	32
3.3	Using the Display	33
3.4	Taking Measurements	35
3.4.1	Foundation Fieldbus Communications	36

**Chapter 4. Specifications**

4.1 General Specifications ..... 39

    4.1.1 Hardware Configuration ..... 39

    4.1.2 Environmental ..... 39

    4.1.3 Flow Accuracy (% of Reading) ..... 39

    4.1.4 Range ..... 39

    4.1.5 Molecular Weight and Mass Flow Accuracy (% of Reading) ..... 40

    4.1.6 Rangeability ..... 40

    4.1.7 Repeatability ..... 40

4.2 Electrical Specifications ..... 40

    4.2.1 Power Supply ..... 40

    4.2.2 Power Usage ..... 40

    4.2.3 Protection ..... 40

    4.2.4 European Compliance ..... 40

    4.2.5 Input/Output Specifications ..... 41

4.3 Operational Specifications ..... 42

    4.3.1 Flow Computer (Built-in) ..... 42

    4.3.2 Data Logging ..... 42

    4.3.3 Display Functions ..... 42

    4.3.4 Printer Signal Output ..... 42

4.4 Transducer/Flowcell Specifications ..... 43

    4.4.1 Transducer Type ..... 43

    4.4.2 Temperature Range ..... 43

    4.4.3 Pressure Range ..... 43

    4.4.4 Materials ..... 43

    4.4.5 Connections ..... 43

    4.4.6 Mounting and Installation ..... 43

4.5 Flowcell Specifications ..... 44

    4.5.1 Spoolpiece ..... 44

    4.5.2 Hot/Cold Tap ..... 44

    4.5.3 Preamplifier with Explosion-proof Housing ..... 44

**Appendix A. CE Mark Compliance**

A.1 Introduction ..... 45

A.2 Wiring ..... 45

A.3 External Grounding ..... 45

**Appendix B. Data Records**

B.1 Option Cards Installed ..... 47

B.2 Initial Setup Data ..... 48

**Appendix C. Optional Enclosures**

C.1 Introduction ..... 51

C.2 Rack Mount Enclosure ..... 51

C.3 Rack Mount Wiring ..... 51

C.1 Rack Mount Front Panel ..... 52

**Appendix D. Measuring P and L Dimensions**

D.1 Introduction ..... 57

D.2 Measuring P and L Distances ..... 57



# Chapter 1. Installation

## 1.1 Introduction

To ensure safe and reliable operation of the Model GF868 flowmeter for flare gas, the system must be installed in accordance with the guidelines established by Panametrics's engineers. This section explains how to install the Model GF868 electronics console and make wiring connections. It covers:

- Unpacking - How to unpack the GF868 system.
- Selecting a suitable site for the electronics console and the flowcell/transducers.
- Installing a flowcell
- Installing temperature and pressure transmitters
- Installing the electronics console
- Wiring the electronics console



**WARNING!** THE MODEL GF868 FLOWMETER MEASURES THE FLOW OF MANY GASES, SOME OF THEM POTENTIALLY HAZARDOUS. WE CANNOT OVEREMPHASIZE THE IMPORTANCE OF SAFETY. BE SURE TO FOLLOW ALL APPLICABLE SAFETY CODES AND REGULATIONS FOR INSTALLING ELECTRICAL EQUIPMENT IN YOUR AREA AND WHEN WORKING WITH PARTICULARLY HAZARDOUS GASES OR FLOW CONDITIONS. CONSULT YOUR COMPANY SAFETY PERSONNEL OR LOCAL SAFETY AUTHORITIES IF YOU ARE UNSURE ABOUT THE SAFETY OF ANY PROCEDURE OR PRACTICE.



**CAUTION!** In order to meet CE Mark requirements, all wiring connections must be made in accordance with the instructions in Appendix A, *CE Mark Compliance*.

## 1.2 Unpacking

Remove the electronics console, transducers, and cables from the shipping containers. Check all packing material before discarding it to account for all parts and documentation listed on the packing slip. If anything is missing or damaged, contact the factory immediately for assistance.

## 1.3 Site Considerations

Since the relative physical locations of the flowcell(s) and the GF868 electronics are important, use the guidelines given in this section when planning your GF868 system installation.

### 1.3.1 Electronics Console Location

Normally, the GF868 electronics enclosure is a Type-4X weather-resistant, dust-tight, indoor/outdoor type. (Other enclosure options are described in Appendix C.) Typically, the electronics console is mounted in a meter shed. If it is not, select a location that allows you access to your meter for programming, testing, and servicing.

**Note:** *For compliance with the European Union's Low Voltage Directive, this unit requires an external power disconnect device such as a switch or circuit breaker. The disconnect device must be marked as such, clearly visible, directly accessible, and located within 6 ft (1.8 m) of the GF868.*

### 1.3.2 Flowcell Location

The pipeline flowcell consists of the flowmeter transducers and any pressure and temperature transducers that may be used as part of the flowmeter system. Ideally, the section of pipe chosen as the flowcell should be a pipe section with easy access; for example, a long stretch of pipe that is above ground. However, if the flowcell must be on an underground pipe, dig a pit around the pipe to facilitate the transducer mechanisms.

### 1.3.3 Transducer Locations

For a given gas and pipe, the Model GF868's accuracy depends primarily on the location and alignment of the transducers on the pipe. In addition to accessibility, when planning for transducer location, consider the following guidelines:

- Locate the transducers so that there are at least 20 pipe diameters of straight, undisturbed flow upstream and 10 pipe diameters of straight, undisturbed flow downstream from the measurement point. To ensure undisturbed flow, avoid: sources of turbulence in the fluid such as valves, flanges, expansions and elbows; swirl; and dips or low spots in which condensed liquid may collect.
- Because condensate or sediment that collects at the bottom of the pipe may cause increased attenuation of the ultrasonic signal, locate the transducers on the side of a horizontal pipe, where possible. If limited pipe access necessitates top-mounted transducers and the sound beam path includes a reflection, shift the transducers to at least 10° off top center. This will minimize the influence of any sediment on the reflected ultrasonic signals.

### 1.3.4 Cable Lengths

Locate the transducers as close as possible to the electronics console. The factory can supply transducer cables up to 500 ft (153 m) in length. For longer distances, consult the factory.

### 1.3.5 Temperature and Pressure Transmitters

When installing temperature and pressure transmitters, locate them downstream of the flowmeter transducers. These transmitters should be positioned no closer to the flowmeter transducers than 2 pipe diameters and no further away from the transducers than 20 pipe diameters.

### 1.3.6 Transducer Cables

When installing the transducer cables, always observe established standard practices for the installation of electrical cables. Specifically, do not route transducer cables alongside high amperage AC power cables, or any other cables that could cause electrical interference. Also, protect the cables and connections from the weather and corrosive atmospheres.

**Note:** *If you are using your own cabling to connect the transducers to the electronics console, the cabling must have electrical characteristics identical to the cable supplied by Panametrics. Cable must be type RG 62 A/U coaxial cable (93  $\Omega$ ) and each cable must be the same length (within  $\pm 4$  in.).*

## 1.4 Installing a Flowcell

A flowcell is the section of pipe where the transducers are mounted. It can be created either by mounting the transducers on the existing pipeline or on a spoolpiece. A spoolpiece is a separately manufactured pipe section, matched to the existing pipe, which contains ports for mounting the transducers. This approach allows the transducers to be aligned and calibrated before mounting the spoolpiece into the pipeline.

Figure 1 on page 4 shows a block diagram of a typical Model GF868 system, including optional pressure and temperature transmitters. For detailed instructions on installing the transducers and/or spoolpiece, refer to the supplied drawings and the Panametrics *Transducer Installation Guide*.



**CAUTION!** **The manual insertion mechanism systems are for low pressure applications (80 psig/5.5 bar or less). Use the appropriate safety precautions when inserting or withdrawing the insertion mechanism.**

## 1.4 Installing a Flowcell (cont.)

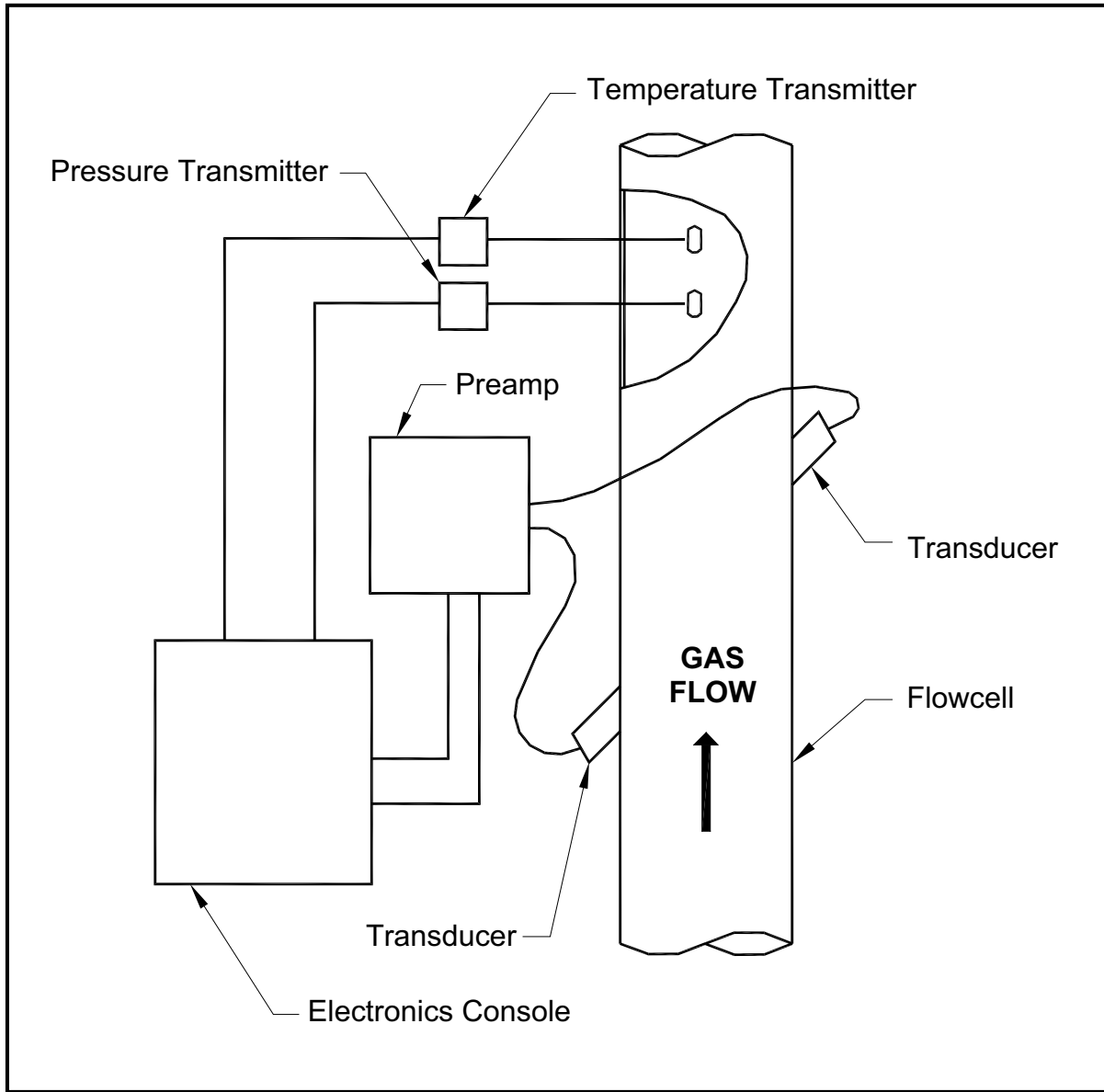

**Figure 1: Model GF868 Flowmeter System**

## 1.5 Installing Temperature and Pressure Transmitters

Temperature and pressure transmitters may be installed as part of the flowcell, near the ultrasonic transducer ports. (Be sure to observe the siting requirements mentioned earlier.) These transmitters must use a 0/4 to 20-mA signal to transmit temperature and pressure values to the GF868 console. The console, in turn, provides 24-VDC power to the transmitter. You can use any desired transmitters or sensors; however, they must have an accuracy of 0.5% of the reading or better.

**Note:** Resistive Thermal Devices (RTDs) are typically used to measure temperature.

Typically, a 1/2" or 3/4" NPT female threaded port is used to mount the transmitters on the flowcell. If the pipeline is insulated, you may need to extend the coupling to provide convenient access. Of course, you may also use other types of mounting ports, including flanged ports, for the transmitters.

The 4 to 20-mA transmitters typically mount directly into the ports as shown in Figure 2. The temperature sensor should protrude 1/4 to 1/2 way into the pipe.

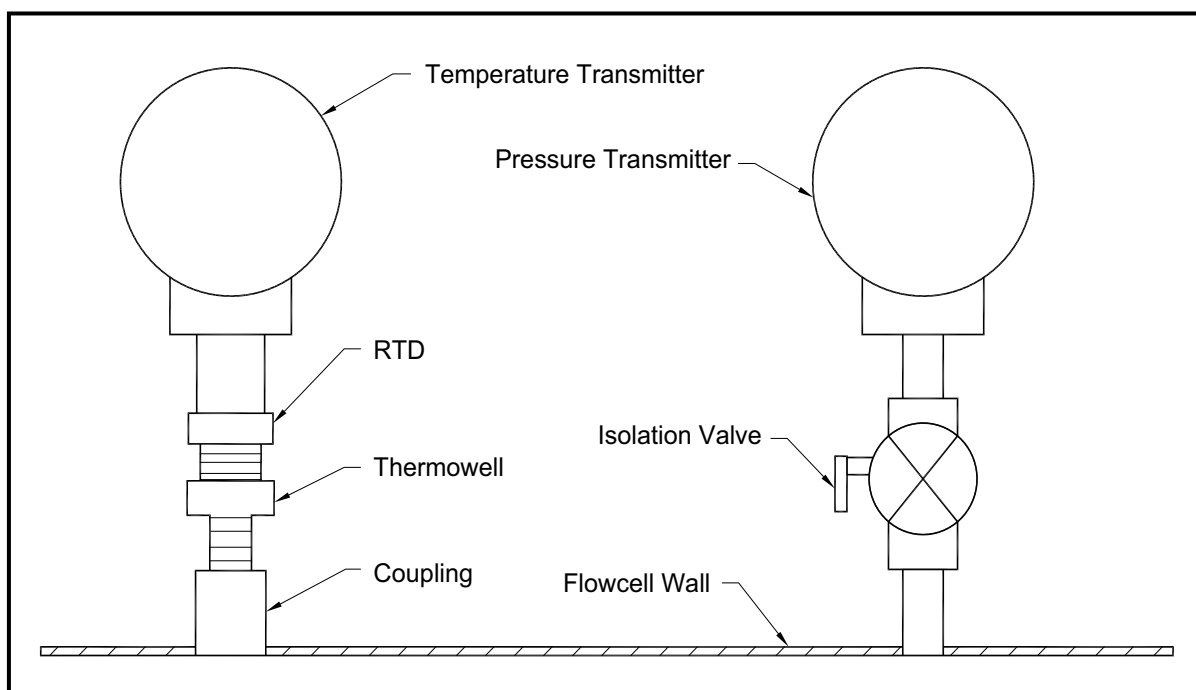

Figure 2: Typical Temperature/Pressure Transmitter Mounting

## 1.6 Mounting the GF868 Enclosure

The standard GF868 is housed in a Type-4X weather-resistant enclosure. Other enclosure options are available, and are discussed in Appendix C. Refer to Figure 8 on page 17 for standard enclosure mounting dimensions. For meters housed in one of the optional enclosures, a dimensional drawing will be shipped with the unit.



**WARNING!** Proper grounding of the GF868 chassis is required to prevent the possibility of electric shock. See Figure 9 on page 18 to locate the internal ground connection.

## 1.7 Making Electrical Connections



**CAUTION!** In order to meet CE Mark requirements, all wiring connections must be made in accordance with the instructions in Appendix A, *CE Mark Compliance*.

This section contains instructions for making all the necessary electrical connections to the Model GF868 flowmeter. See Figure 9 on page 18 for a complete wiring diagram.



**WARNING!** RACK MOUNT CUSTOMERS: Refer to Appendix C for a wiring diagram and installation information for your unit.

Except for the power connector, all terminal blocks are stored in their terminal blocks during shipment and are removable for more convenient wiring. Feed all cables through the conduit holes on the bottom of the enclosure, attach the wires to the appropriate connectors, and plug the connectors back into their terminal blocks.



**WARNING!** To ensure the safe operation of the Model GF868, you must install and operate it as described in this manual. In addition, be sure to follow all applicable safety codes and regulations for installing electrical equipment in your area.

**Note:** If your unit complies with the European Union's Low Voltage Directive, it has a transparent plastic cover over the electrical connections. This cover must remain in place except while you are wiring your unit. Reinstall the shroud after the wiring has been completed.

Once the GF868 is completely wired, proceed to Chapter 2, *Initial Setup*, to configure the unit for operation.

### 1.7.1 Wiring the Line Power



**CAUTION!** In order to meet CE Mark requirements, all wiring connections must be made in accordance with the instructions in Appendix A, *CE Mark Compliance*.

The Model GF868 may be ordered with power inputs of 100-120 VAC, 220-240 VAC, or 12-28 VDC. The label on the shroud inside the electronics enclosure, just above the TB1 line power terminal block, lists the line voltage setting and fuse rating for your unit. (The fuse rating also appears in Chapter 4, *Specifications*.) Be sure to connect the meter only to the correct line voltage. The allowable line voltages and fuse ratings are shown in Table 1 on page 9.

**Note:** For compliance with the European Union's Low Voltage Directive, this unit requires an external power disconnect device such as a switch or circuit breaker. The disconnect device must be marked as such, clearly visible, directly accessible, and located within 6 ft (1.8 m) of the GF868.

**Note:** Only use Class 2 Rated Power supply for line power connection to DC instrument.

## 1.7.1 Wiring the Line Power (cont.)

Refer to Figure 3 on page 7 or Figure 9 on page 18 to locate terminal block TB1 and connect the line power as follows:



**WARNING!** Improper connection of the line power leads, or connecting the meter to the incorrect line voltage, will damage the unit. It will also result in hazardous voltages at the flowcell and associated piping and within the electronics console.

1. Remove the plastic shroud that covers the terminal blocks. Be sure to reinstall the shroud after all of the wiring has been completed.
2. Strip  $\frac{1}{4}$ " of insulation from the end of the power and neutral or line leads (or the positive and negative DC power leads), and  $\frac{1}{2}$ " from the end of the ground lead.
3. Connect the ground lead to the internal ground connection located on the side panel of the enclosure (see Figure 3 below).

**IMPORTANT:** The incoming ground lead must be connected to the internal ground connection.

4. Connect the neutral or line lead (or the negative – DC power lead) to TB1-2 and the line power lead (or the positive + DC power lead) to TB1-3 as shown in Figure 3 below.

**IMPORTANT:** Do not remove the existing PC board ground wire or the cover ground wire.

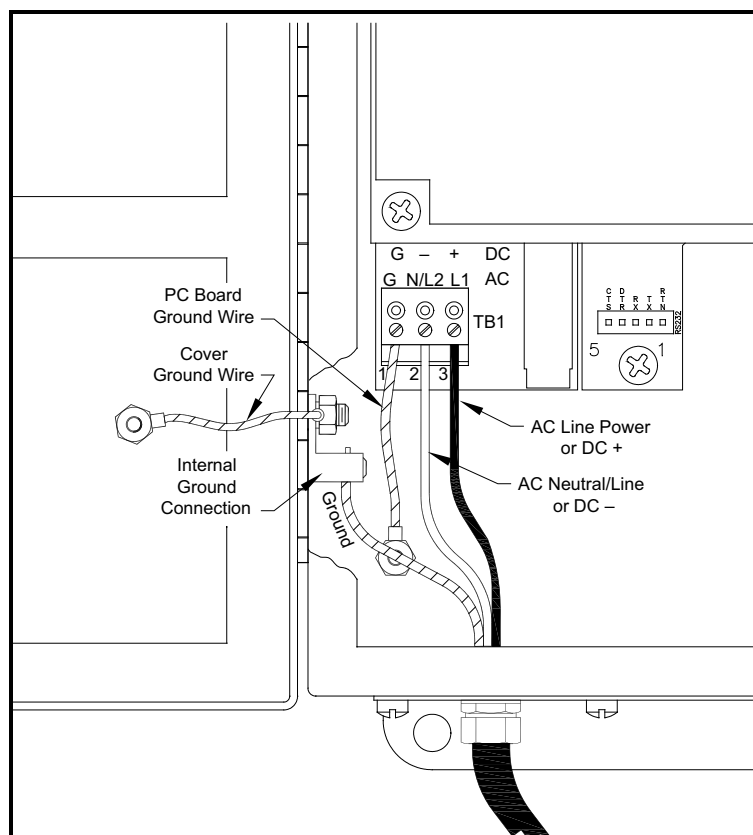

Figure 3: Wiring the Line Power

## 1.7.2 Wiring the Transducers



**CAUTION!** In order to meet CE Mark requirements, all wiring connections must be made in accordance with the instructions in Appendix A, *CE Mark Compliance*.

Wiring the GF868 ultrasonic flare gas flowmeter system requires interconnection of the following components:

- a pair of transducers mounted in the flowcell
- a preamplifier for each channel
- an optional lightning protector
- the GF868 console.

Use a coaxial cable to make all connections between the console and the transducers. Connect the transducers to terminal block CH1 as shown in Figure 9 on page 18 and Figure 10 on page 19.



**WARNING!** Before connecting the transducers, discharge any static buildup in a safe area, by shorting the center conductor of the transducer cables to the metal shield of the cable connector.

## 1.7.3 Wiring the 0/4-20 mA Analog Outputs

The standard GF868 comes with two isolated 0/4-20 mA analog outputs (A and B). Use standard twisted-pair wiring to make connections to these outputs. The current loop impedance must not exceed 550 ohms.

Refer to Figure 9 on page 18 and connect the wires to the terminal block I/O as shown.

## 1.7.4 Wiring the Serial Port

The Model GF868 is equipped with a built-in serial communications port. The standard port is an RS232 interface, but an optional RS485 interface is available upon request. Proceed to the appropriate sub-section for wiring instructions. For more information on serial communications, refer to the *EIA-RS Serial Communications Manual* (916-054).



### 1.7.4.1 Wiring the RS232 Interface

The RS232 communications port provides a serial interface in order to connect the GF868 to a printer, an ANSI terminal or a personal computer.

The RS232 serial interface is wired as Data Terminal Equipment (DTE), and the signals available at the GF868 RS232 terminal block are shown in Table 1 below. Refer to Figure 9 on page 18 to locate terminal block RS232 and complete the following steps to wire the terminal:

1. Use the information in Table 1 to construct a suitable cable for connecting the GF868 to the external device. (If desired, an appropriate cable may be purchased from the factory.)

**Table 1: RS232 Connection to DCE or DTE Device**

RS232 Pin #	Signal Description	DCE DB25 Pin #	DTE DB25 Pin #	DTE DB9 Pin #
1	RTN (Return)	7	7	5
2	TX (Transmit)	2	3	3
3	RX (Receive)	3	2	2
4	DTR (Data Terminal Ready)	20	20	4
5	CTS (Clear to Send)	5	4	8

2. Wire the flying leads end of the cable to terminal block RS232 and connect the other end of the cable to the printer, ANSI terminal or personal computer.

After the wiring has been completed, consult the User's Manual for the external device to configure it for use with the GF868.

### 1.7.4.2 Wiring the RS485 Interface

Use the optional RS485 serial port to network multiple GF868 flowmeters to a single computer terminal. Upon request, the standard RS232 port on the GF868 may be configured as a two-wire, half-duplex RS485 interface, through a device such as the INMAC Model 800052 RS232-RS422/RS485 converter.

To wire the RS485 serial port, refer to Figure 9 on page 18 and complete the following steps:

1. Disconnect the main power to the unit and remove the cover.
2. Install the required cable clamp in the chosen conduit hole on the side of the electronics enclosure.
3. Feed one end of the cable through the conduit hole, wire it to terminal block J1 and secure the cable clamp. Connect the other end of the cable to the converter, as shown in Figure 4.

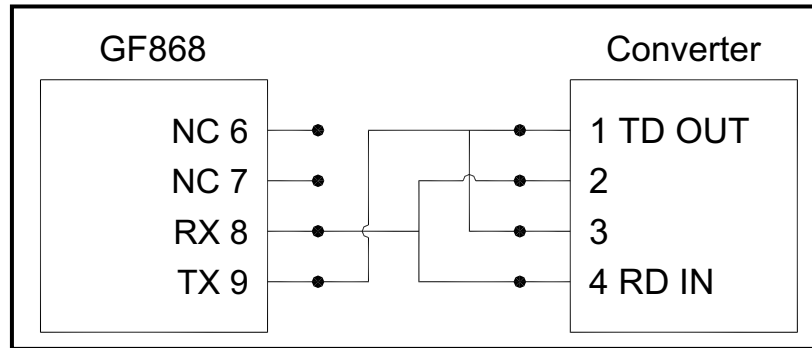

**Figure 4: Typical RS485 Connections**



**WARNING!** To meet CE Mark requirements, all wiring connections must be installed as described in Appendix A, *CE Mark Compliance*.

4. If wiring of the unit has been completed, reinstall the plastic shroud, close the cover on the enclosure and tighten the latches.
5. Connect the converter to the control system, as described in its User's Manual.

### 1.7.4.3 Wiring the Ethernet Interface

A modified GF868 can use the Ethernet interface to communicate to an internal network. An optional Ethernet card with a unique MAC (IP) address (installed only in slots 5 or 6) includes an RJ45 connector. To connect the Ethernet-enabled GF868 to the network, insert the jack of an RJ45 cable into the RJ45 connector, route the cable through the bottom of the GF868, and wire the other end of the cable to the Ethernet network according to the manufacturer's instructions. An external connection is required between the Ethernet option card and the GF868's RS232 connector, as shown in Table 2.

**Note:** The MAC address for a specific GF868 is included with customer documentation. For more information on setting up the MAC address, refer to Chapter 6 of the Programming Manual.

**Table 2: RS232 to Ethernet Interconnections**

GF868 Type	Terminal Block	Terminal Block
Wall Mount	RS232 on Main Board	TB1 on Ethernet Card
	TX	Pin 1
	RX	Pin 2
	RTN	Pin 3
Rack Mount	RS232 on Main Board	TB2 on Ethernet Card
	TX	Pin 1
	RX	Pin 2
	RTN	Pin 3

### 1.7.4.4 Wiring the MODBUS/TCP Interface

Customers can also use a modified GF868 that provides a MODBUS/TCP interface to communicate to an internal network. An optional MODBUS/TCP card with a unique MAC (IP) address (installed only in slots 5 or 6) includes an RJ45 connector. To connect the MODBUS/TCP-enabled GF868 to the network, insert the jack of an RJ45 cable into the RJ45 connector, route the cable through the bottom of the GF868, and wire the other end of the cable to the Ethernet network according to the manufacturer's instructions.

**Note:** The MAC address for a specific GF868 is included with customer documentation. For more information on setting up the MAC address, refer to Chapter 6 of the Programming Manual.

### 1.7.4.5 Wiring the Foundation Fieldbus Network

Fieldbus network connections are made at J8/J9, pins 1 and 2 (see Figure 5). Optionally, a shield can be connected to J8/J9 pin 3, depending on the network wiring. Connector J8 or J9 will be installed depending on the option ordered by the customer.

No connections are made to J8/J9, pins 7 and 9, under normal operation. If it is desired to reset the network board to factory defaults:

1. Connect a jumper between J8/J9 pin 7 and pin 9.
2. Power cycle the instrument.
3. Ten seconds after the power has been restored to the unit, remove the jumper to return the network board to normal operation.

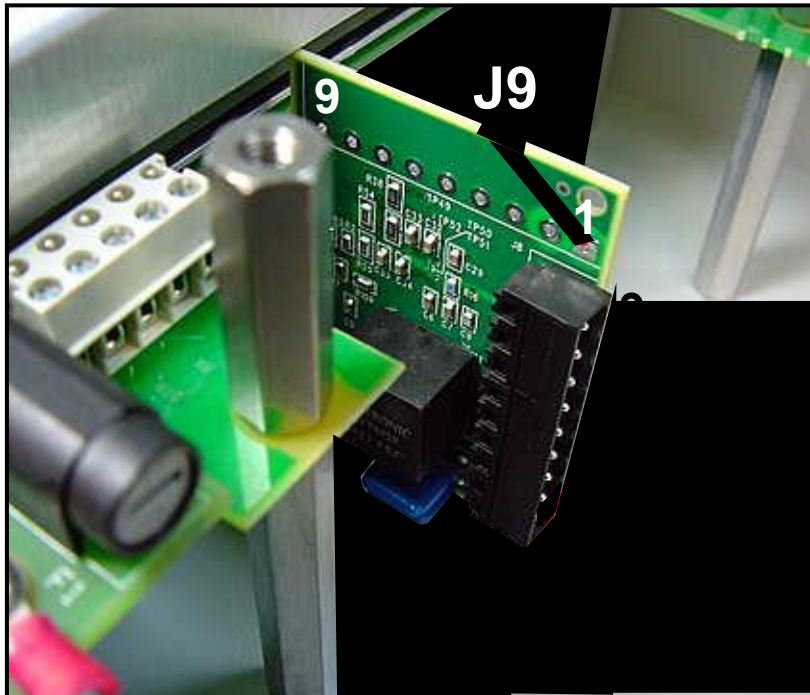

Figure 5: Network Connections - Standard Option Interior

### 1.7.5 Wiring an Alarms Option Card

The GF868 can accommodate 1 to 6 alarm option card(s). Each alarm option card provides three Form C relays (A, B and C). The alarm relays on the option card are available in two types:

- general-purpose
- hermetically-sealed for Class I, Division 2 hazardous areas.

Chapter 4, *Specifications*, lists the maximum electrical ratings for the relays. Each alarm relay can be wired as *Normally Open (NO)* or *Normally Closed (NC)*.

In setting up an alarm relay, it may be wired for either *conventional* or *fail-safe* operation. In fail-safe mode, the alarm relay is constantly energized, except when it is triggered or a power failure or other interruption occurs. See Figure 6 for the operation of a NO alarm relay in both conventional and fail-safe mode.

Connect the two alarm wires required for each relay in accordance with the pin number assignments shown in Figure 9 on page 18.

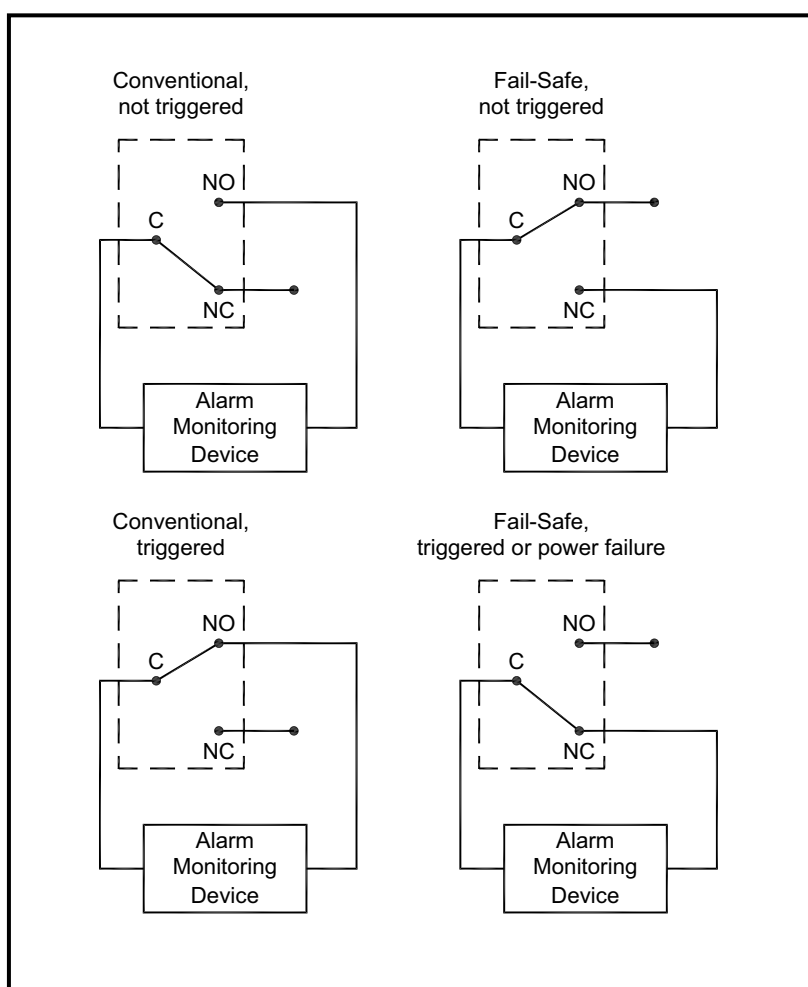

**Figure 6: Conventional and Fail-Safe Operation**

## 1.7.6 Wiring a 0/4-20 mA Analog Inputs Option Card

To calculate standard volumetric flow and mass flow of Flare Gas, the GF868 must have *temperature* and *pressure* data from the measurement site. Transmitters installed in the flowcell send this information to the analog input card. This card provides two isolated 4-20 mA inputs (A and B) with 24 VDC supply for loop-powered transmitters. You can assign the temperature and pressure inputs to A and B as desired.

**Note:** *To enter programming data during meter operation, you should know which input is assigned to which process parameter. Enter the connections in Appendix B, Data Records.*

The analog inputs, which have an impedance of 118 ohms, should be connected with standard twisted-pair wiring. Temperature and pressure inputs require two or four wires, depending on whether the GF868 will provide power to the transmitter. If desired, INLO and RTN can use the same wire.

Wire the analog input terminal block in accordance with the pin number assignments shown in Figure 9 on page 18.

The analog inputs on the option card(s) can be calibrated with the Model GF868's built-in analog outputs. However, be certain that the analog outputs have been calibrated first. See Chapter 1, *Calibration*, in the *Service Manual* for the appropriate procedures.

### 1.7.7 Wiring the Totalizer/Frequency Outputs

The GF868 can accommodate 1 to 6 totalizer/frequency outputs option cards. Each totalizer/frequency outputs option card provides four outputs (A, B, C, and D) that can be used as either totalizer or frequency outputs.

Each totalizer/frequency output requires two wires. Wire this terminal block in accordance with the pin number assignments shown in Figure 9 on page 18. Figure 7 shows sample wiring diagrams for the totalizer/frequency outputs.

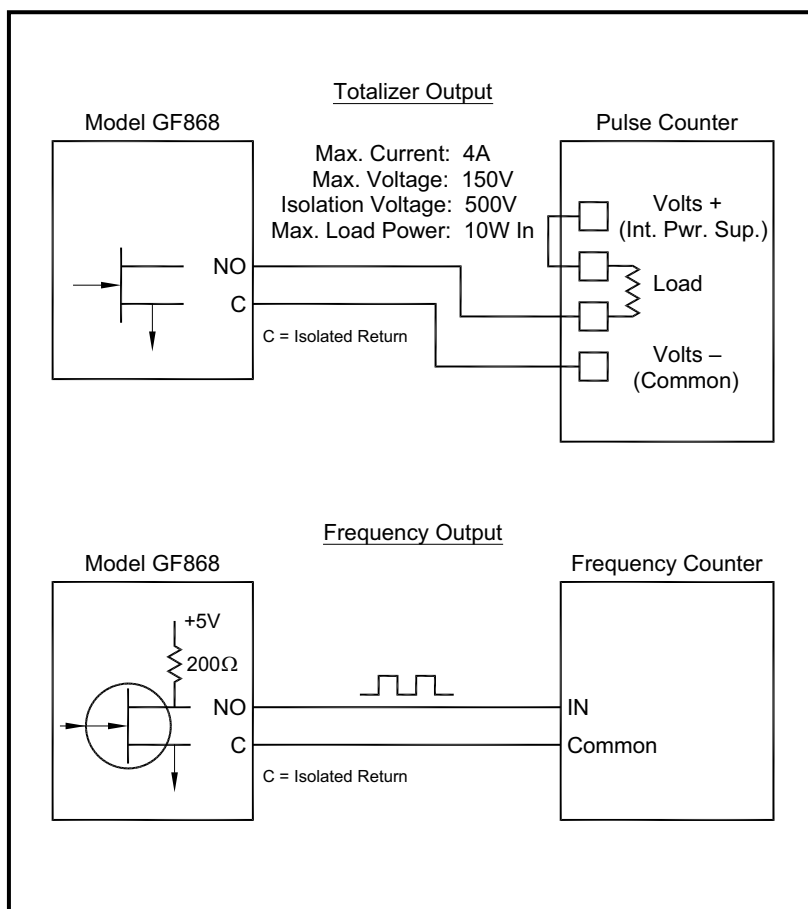

**Figure 7: Totalizer/Frequency Output Wiring**

### 1.7.8 Wiring the RTD Inputs

The GF868 can accommodate 1 to 6 RTD (Resistance Temperature Device) inputs card(s). Each RTD inputs card provides two direct RTD inputs (A and B).

Each RTD input requires three wires. Feed the wires through one of the conduit holes on the bottom center of the enclosure. Connect the wires to the 8-pin RTD inputs option card terminal block as shown in Figure 9 on page 18.

[no content intended for this page]



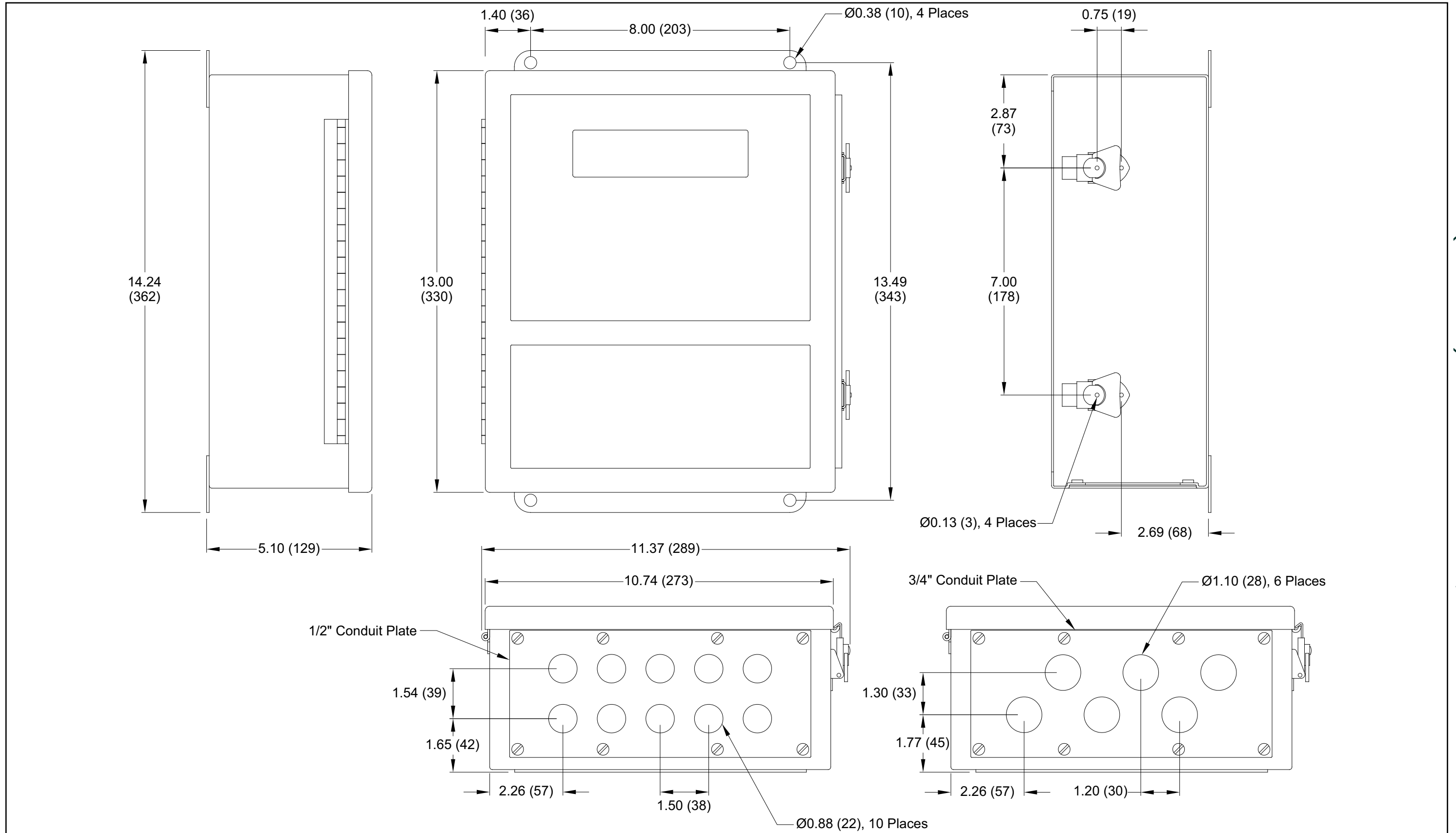

Figure 8: Model GF868 Type 4X Enclosure (ref. dwg #425-208)

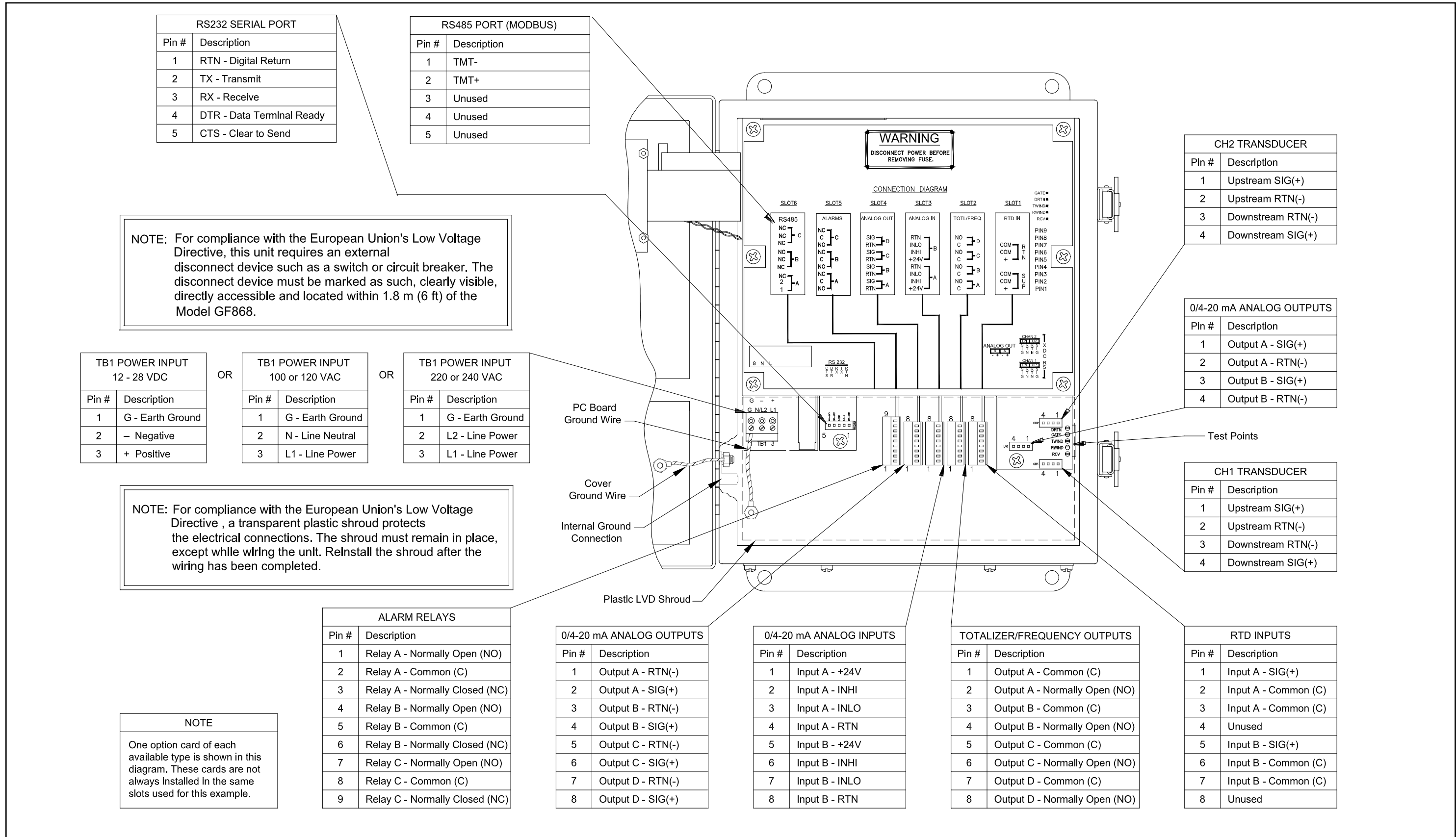
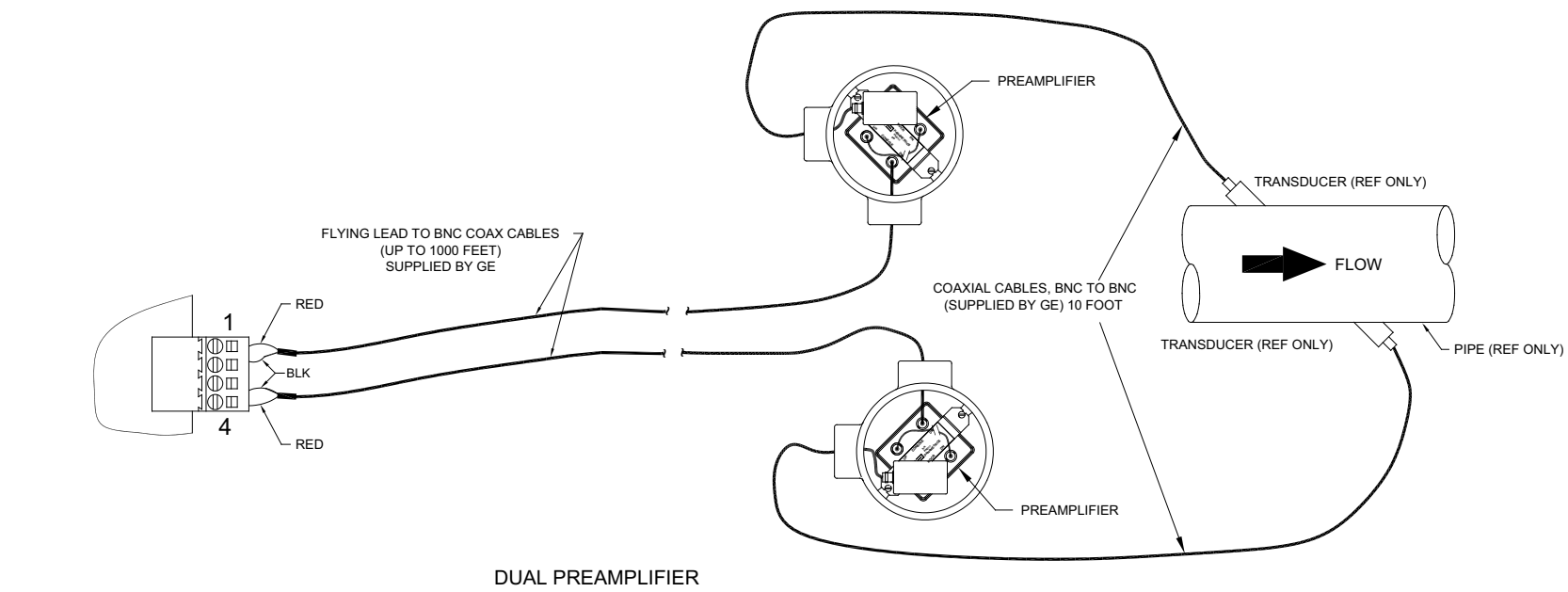

Figure 9: Model GF868 Electronics Console Wiring (ref. dwg #702-213, sht 1)



**CAUTION!**  
As part of maintaining the FM/CSA environmental rating (NEMA/TYPE 4) on the remote preamplifier, thread sealant is required on all conduit entries.

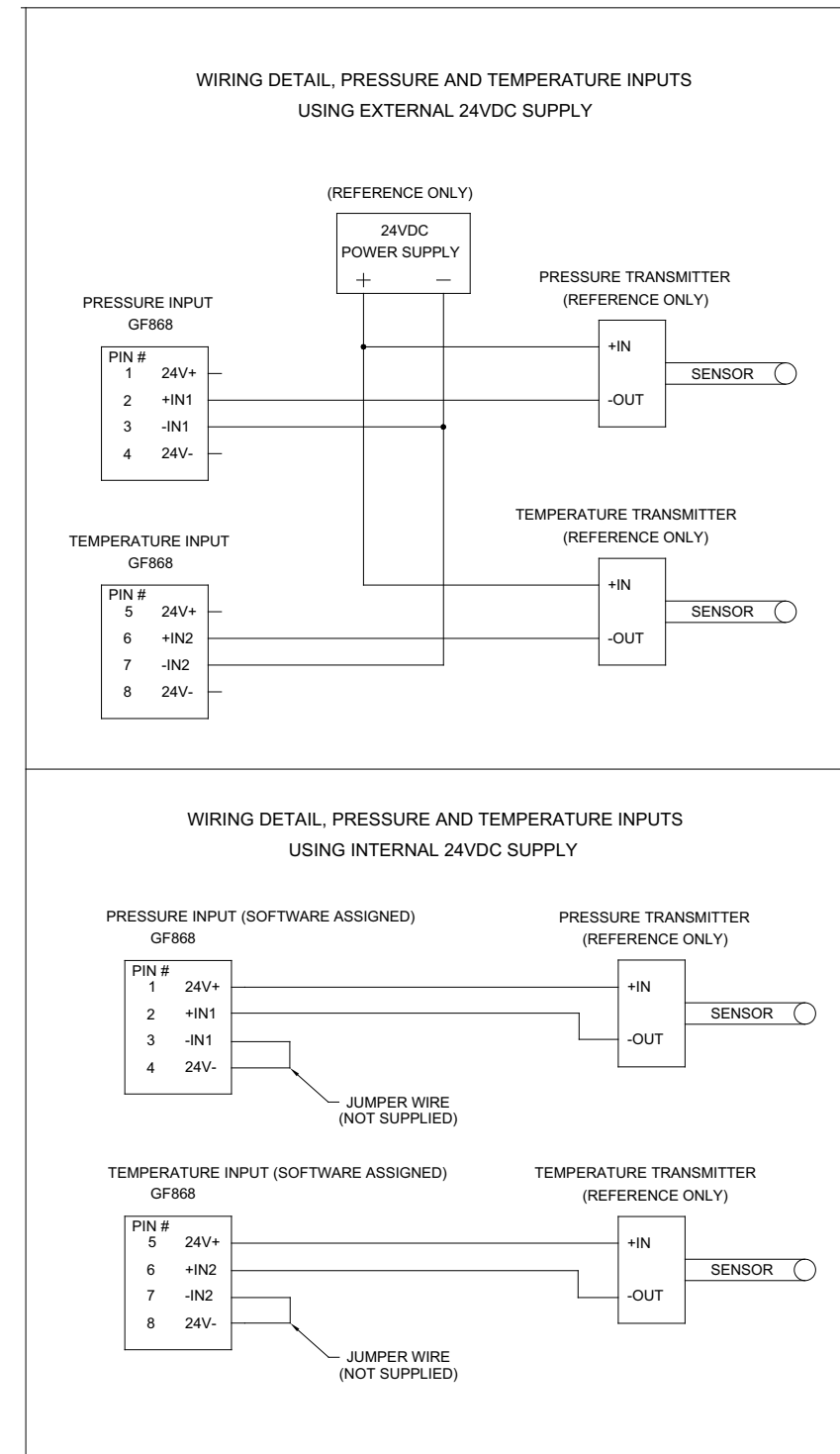
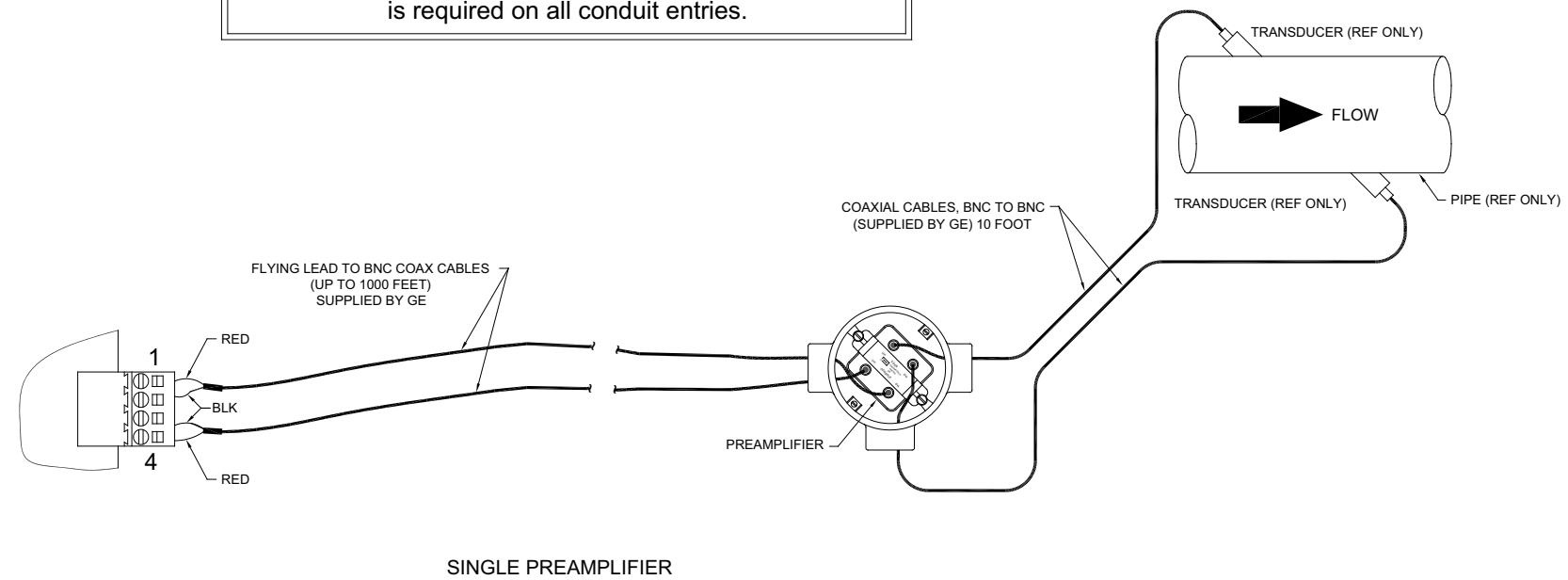

Figure 10: Model GS868 Transducer Wiring (ref. dwg #702-213, sht 2 of 2)



## Chapter 2. Initial Setup

### 2.1 Introduction

This chapter provides instructions for entering the minimum amount of programming data required to place the GF868 flowmeter into operation. Before your GF868 can begin taking measurements, you must enter the necessary information into the **SYSTEM** and **PIPE** submenus. In addition, a 2-Channel meter requires activation of each channel prior to use. The other submenus within the Program Menu enable you to access all the GF868 features; however, this information is not necessary to begin taking measurements.

**Note:** See the Programming Manual for information on those User Program options not covered in this chapter.

### 2.2 Navigating Through the User Program

To begin using the GF868, you must access three submenus within the User Program:

- **ACTIV** – enables you to select a measurement method.
- **SYSTEM** – prompts you to enter the required system information.
- **PIPE** – lets you enter the necessary pipe data.

As a guide in following the programming instructions in this chapter, the relevant portions of the GF868 menu map appear in Figure 11 on page 29.

**Note:** There are minor differences at the start of the **ACTIV** and **SYSTEM** submenus for the 1-Channel and 2-Channel models, but the **PIPE** submenus are identical.

The following discussion assumes that the left screen is active. If the right screen is active, only the function key designations change – **[F1]** becomes **[F5]**, etc. Be sure to record all programming data in Appendix B, *Data Records*.

Use the keypad, as described in the *Programming Manual*, to navigate through the *User Program*. The menu map may be followed in sequence, or the [**←**] and [**→**] keys may be used to scroll through the prompt screens. The [**←**] key may be used to delete the last alphanumeric character that was entered from the keypad.

## 2.3 Accessing the User Program

To enter the Program Menu, press the [PROG] key on the keypad.

**Note:** *Note: If the security feature is active, the GF868 will prompt you for a password. Enter the password and press [ENT]. See the SECUR submenu section in Chapter 1, Programming Site Data, of the Programming Manual for more information on the security feature.*

### 2.3.1 1-Channel Meter

For a 1-Channel Model GF868, the measurement mode screen is replaced by the following initial programming mode screen:

PROGRAM	Start ▶	At the <i>User Program</i> screen shown, press the [F1] function key and proceed to “ <i>Activating a Channel</i> ” on the next page		
PROGRAM status				
ACTI	SYST		PIPE	I/O

### 2.3.2 2-Channel Meter

For a 2-Channel Model GF868, the following two-step sequence is required to reach the initial programming screen:

PROGRAM	Start ▶	Press [F1] or [F2] to select the submenu for Channel 1 or Channel 2, respectively, from the option bar.		
PROGRAM Channel 1				
CH1	CH2		GLOB	SAVE

Chan 1	PROGR	Start ▶	At the <i>User Program</i> screen shown, press the [F1] function key and proceed to “ <i>Activating a Channel</i> ” on the next page	
Channel PROGRAM status				
ACTI	SYST	PIPE		I/O

Only the submenus **ACTIV**, **SYSTEM** and **PIPE** are discussed in this manual. Refer to the *Programming Manual* for information on the other submenus.

**Note:** *In this manual, only the programming of Channel 1 will be described. To program Channel 2, simply repeat the same procedures presented for Channel 1.*

## 2.4 Activating a Channel

The **ACTIV** submenu permits selection of the desired measurement method. In addition, it is used to activate/deactivate one or both of the channels in a 2-Channel Model GF868.

### 2.4.1 1-Channel Meter

1. Enter the **ACTIV** submenu by pressing **[F1]** at the **User PROGRAM** prompt.
2. Press **[F1]** to activate the channel in **BURST** mode.

### 2.4.2 2-Channel Meter

1. Enter the **ACTIV** submenu by pressing **[F1]** at the **Channel PROGRAM** prompt.
2. Press **[F1] (OFF)** to deactivate the channel and return to the **Channel PROGRAM** prompt, or press **[F2]** to activate the channel in **BURST** mode.

### 2.4.3 1 and 2-Channel Meters

1. Press **[F1]** to select *Skam* mode or **[F2]** to select *Skam/Measure* mode. The meter will exit the **ACTIV** submenu and return to the channel menu screen.

As indicated in the above prompt, the Model GF868 flowmeter can take measurements in two different ways

**Skam** is a low resolution technique for locating the acoustic signal and for high velocity measurements. It is more robust in a noisy environment than the Measure technique.

**Measure** is a more precise technique best used for low velocity measurements.

If *Skam* is selected at the next prompt, the instrument uses this technique exclusively. However, if *S/M* is selected, the meter uses *Skam* to find the acoustic signal and then tries to use the *Measure* technique for a more precise measurement.

Proceed directly to the next section to program the **SYSTEM** submenu.

## 2.5 Entering System Data for a Channel

Begin programming the **SYSTM** submenu in either the *1-Channel* or *2-Channel* section below.

### 2.5.1 A 1-Channel Meter

For the 1-Channel Model GF868, the information entered in the **SYSTM** submenu pertains to the global operation of the flowmeter.

1. At the *User Program* screen, press the **[F2]** function key to program the **SYSTM** submenu.
2. Enter a *Site Label* of up to 9 characters and press **[ENT]**. (While taking measurements, the site label will appear on the locator bar.)
3. Enter a *Site Message* of up to 21 characters. Press **[ENT]**.
4. To select the *System Units*, press **[F1]** to display parameters and measurements in English units, or press **[F2]** to display parameters and measurements in Metric units.
5. Use the **[F1]**-**[F4]** keys to select the type of *Pressure Units* desired.

The abbreviations and definitions of all the available pressure units are shown in Table 3 below. The choices shown on the option bar are determined by the selections made at the previous SYSTEM UNITS prompt.

**Table 3: Available Pressure Units**

English	Metric
PSIa = Pounds per square inch absolute	BARa = bar absolute
PSIg = Pounds per square inch gage	BARg = bar gage
	kPa <sub>a</sub> = kiloPascals absolute
	kPag = kiloPascals gage

- a. If you have entered gage pressure, or the local atmospheric pressure (PSIg, BARg or kPag), use the numeric keys to enter the gage pressure value. Press **[ENT]**.
6. At the *Stopwatch Totalizer* prompt, press **[F1]** to totalize all liquid flow continuously, or **[F2]** to measure totals manually with the Stopwatch Timer. (With MNUAL (**[F2]**), the console key on the keypad is used to start and stop the totalizer. See the *Programming Manual* for details.)

The remainder of the **SYSTM** submenu is identical for the 1-Channel and 2-Channel versions of the Model GF868. Proceed to the *1- and 2-Channel Meters* section to complete the programming of this submenu.



## 2.5.2 A 2-Channel Meter

For the 2-Channel Model GF868, the information entered in the **SYSTEM** submenu pertains only to the currently selected channel.

1. At the *User Program* screen shown, press the **[F2]** function key to program the **SYSTEM** submenu.
2. Enter a *Channel Label* of up to 9 characters. Press **[ENT]**.
3. Enter a *Channel Message* of up to 21 characters. Press **[ENT]**.

**Note:** For the 2-Channel Model GF868, the *System Units, Pressure Units and Stopwatch Totalizer prompts, which are not required to make the unit operational, are located in the GLOBL submenu. See the Programming Manual for details.*

The remainder of the **SYSTEM** submenu is identical for the 1-Channel and 2-Channel versions of the Model GF868. Proceed to the *1- and 2-Channel Meters* section below to complete the programming of this submenu.

## 2.5.3 1 and 2-Channel Meters

1. Use the **[F1]**-**[F4]** and **[→]** keys to select the desired *Volumetric Units* for the flow rate display.

The abbreviations and definitions of all the available volumetric and totalizer units are shown in Table 4. The choices shown on the option bar are determined by the selection made at the previous **SYSTEM UNITS** screen.

**Table 4: Available Volumetric/Totalizer Units**

English	Metric
Actual Units	
ACF = Actual Cubic Feet	ACM = Actual Cubic Meters
KACF = Thousands of ACF	KACM = Thousands of ACM
MMACF = Millions of ACF	MMACM = Millions of ACM
Standard Units	
SCF = Standard Cubic Feet	SCM = Standard Cubic Meters
KSCF = Thousands of SCF	KSCM = Thousands of SCM
MMSCF = Millions of SCF	MMSCM = Millions of SCM

2. Use the **[F1]**-**[F4]** keys to select the *Volumetric Time* (units for the volumetric flow rate display).
3. Use the **[F1]**-**[F4]** keys to select the *Vol Decimal Digits* (the desired number of digits to the right of the decimal point) in the volumetric flow rate display.

### 2.5.3 1- and 2-Channel Meters (cont.)

4. Use the **[F1]-[F4]** and **[→]** keys to select the *Totalizer Units*.

The abbreviations and definitions of all the available volumetric and totalizer units are shown in Table 2-2 on the previous page. The choices shown on the option bar in the prompt screen above are determined by the selection made at the previous **SYSTEM UNITS** prompt screen.

5. Use the **[F1]-[F4]** keys to select the *Total Decimal Digits* (the desired number of digits to the right of the decimal point) in the totalized flow display.
6. Use the **[F1]-[F4]** keys to select the *Mass Flow* units, listed in Table 5.

**Table 5: Available Mass Flow Units**

English Mass Flow Units	Metric Mass Flow Units
LB- Pounds	KG - Kilograms
KLB - Thousands of Pounds	
MMLB - Millions of Pounds	
TONS -Tons	Tonnes - Metric Tons

7. Use the **[F1]-[F4]** keys to select the *Mass Flow Time* units.
8. Use the **[F1]-[F4]** keys to select the *MDOT DECIMAL DIGITS* (the number of digits to the right of the decimal point) for displaying mass flow.
9. Use the **[F1]-[F4]** keys to select the *Mass (Totalizer)* units, listed in Table 5 above.
10. Use the **[F1]-[F4]** to specify the *Mass Decimal Digits* (the number of digits to the right of the decimal point) for displaying totalized mass flow. The meter returns to the initial *User (or Channel) Program* screen.

Proceed directly to the next section to program the **PIPE** submenu.

## 2.6 Entering Pipe Data

The **PIPE** submenu permits entry of the transducer and pipe specifications. To program this menu, complete the following steps:

1. At the *User (or Channel) Program* screen, press **[F3]** to program the **PIPE** submenu.

### 2.6.1 Transducer Number

2. Enter the *Transducer Number* (normally engraved on the head of the transducer). Press **[ENT]**. If there is no engraved number, complete the steps below. Otherwise, proceed to step 3.

**IMPORTANT:** Special transducers, which have no engraved number on the head, are rarely used. Examine the transducer head carefully for a number.

- a. Assign a number between 91 and 99 to the *Special Transducer* and press **[ENT]**. (The meter will only accept values from 1 to 199.)
- b. Use the **[→]** and **[F1]–[F4]** keys to select the *Frequency* of the special transducer. The meter can not transmit an excitation voltage at the transducer's natural frequency without this data.
- c. Enter the special transducer *Time Delay* ( $T_w$ ) value supplied by the factory. Press **[ENT]**. (The meter will only accept values from 0 to 1000  $\mu$ sec.)

**Note:**  $T_w$  is the time required for the transducer signal to travel through the transducer and its cable. This time delay must be subtracted from the transit times of the upstream and downstream transducers to ensure an accurate measurement.

### 2.6.2 Pipe OD

3. Enter the known *Pipe OD* or circumference and use the **[F1]–[F4]** keys to select the appropriate units. Press **[ENT]**. (The meter will only accept values from 1/8 to 648 in.) The option bar choices may appear in English or Metric units.

Obtain the required information by measuring either the pipe outside diameter (OD) or circumference at the transducer installation site. The data may also be obtained from standard pipe size tables. Table 6 lists the available English and metric OD units.

**Table 6: Available Pipe OD Units**

English	Metric
inch = pipe OD in inches	mm = pipe OD in millimeters
feet = pipe OD in feet	m = pipe OD in meters
in/PI = pipe circumference in inches	mm/PI = pipe circumference in millimeters
ft/PI = pipe circumference in feet	m/PI = pipe circumference in meters

### 2.6.3 Pipe Wall

4. Use the numeric keys to enter the known thickness of the *Pipe Wall*. Press **[ENT]**.

If the pipe wall thickness is not available, look up the value in a table of standard pipe size data or use the Model GF868's on-line *Help Menu* (see the *Programming Manual* for details).

### 2.6.4 Path Length

5. Press **[F1]** = inch or **[F2]** = feet to select the units. Then, enter the *Path Length (P)* of the ultrasonic signal. Press **[ENT]**. (The meter will only accept values from 1/8 to 900 in.)

**Note:** *The factory has calculated both the transducer signal path length (P) and the transducer signal axial length (L), based on the exact transducer configuration used for the application. These values are engraved on the flowcell and/or are included in the documentation supplied with the meter.*

### 2.6.5 Axial Length

6. Press **[F1]** = inch or **[F2]** = feet to select the units. Then, enter the *Axial Length (L)* of the ultrasonic signal and press **[ENT]**.

**Note:** *The factory has calculated both the transducer signal path length (P) and the transducer signal axial length (L), based on the exact transducer configuration used for the application. These values are engraved on the flowcell and/or are included in the documentation supplied with the meter.*

### 2.6.6 Reynolds Correction

7. Press **[F1]** to turn *Reynolds Correction* off, or **[F2]** to turn it on.

**Note:** *Reynolds Correction is a number based on the Kinematic Viscosity and flow rate of the fluid. It should be enabled for most applications.*

- a. When you enable the Reynolds Correction Factor, you must also enter the *Kinematic Viscosity* of your gas, as listed in *Sound Speeds and Pipe Size Data*. Use the numeric keys to enter a value, and press **[ENT]**.
8. Enter a value for the flow *Calibration Factor* and press **[ENT]**. The default value is 1.00. (The meter will only accept values from 0.5000 to 2.0000.)

#### 2.6.6.1 Further Options

After completing the above steps, the meter returns to the **User (or Channel) PROGRAM** prompt. Continue as follows:

- To continue programming the meter, refer to the menu maps in Appendix A of the *Programming Manual* and navigate to the desired menu. Then, proceed to the appropriate section of the manual for instructions.
- To leave the *User Program* and retain the previous settings, press **[EXIT]** once (for a 1-channel GF868) or twice (for a 2-channel GF868) and then press **[F1] = NO** at the *SAVE* prompt. Any programming changes will be discarded and you will be returned to the data display.
- To leave the *User Program* and return to measurement mode, press **[EXIT]** once (for a 1-channel GF868) or twice (for a 2-channel GF868) and then press **[F2] = YES** at the *SAVE* prompt. Your programming changes will be entered into the meter's memory, and you will be returned to the data display.

**Note:** *See the Programming Manual for instructions on using the SAVE submenu.*

Proceed to Chapter 3, *Operation*, for instructions on taking measurements or refer to the *Programming Manual* for instructions on programming the Model GF868's advanced features.

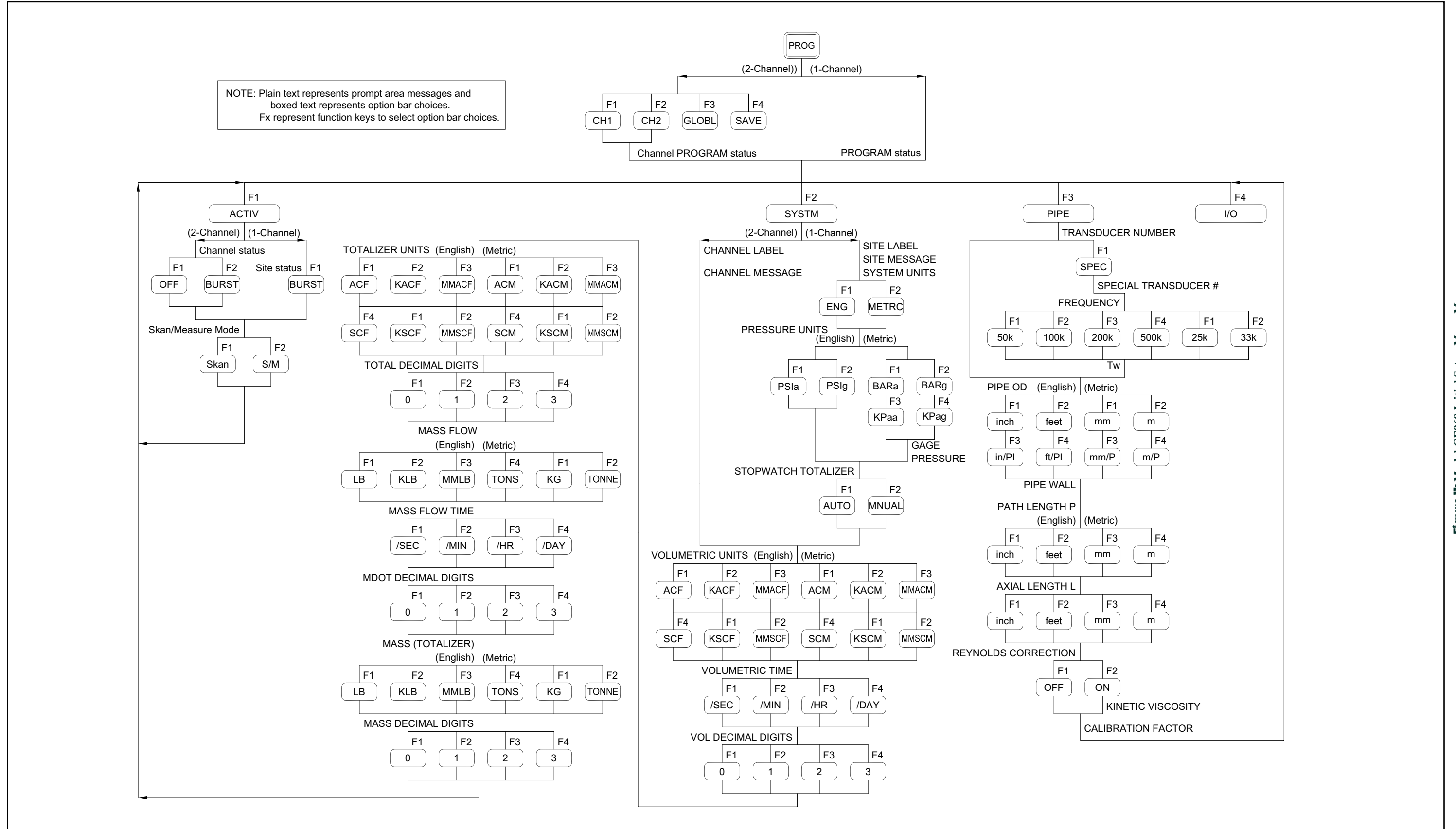

Figure 11: Model GF868 Initial Setup Menu Map



---

## Chapter 3. Operation

### 3.1 Introduction

See Chapter 1, *Installation*, and Chapter 2, *Initial Setup*, to prepare the system for operation. When the meter is ready to take measurements, proceed with this chapter. The following specific topics are discussed:

- Powering Up
- Using the Display
- Taking Measurements

**Note:** *All inputs and outputs of the Model GF868 are calibrated at the factory, prior to shipment. If it becomes necessary to recalibrate any of the inputs and/or outputs, see Chapter 1, Calibration, of the Service Manual.*



**WARNING!** To ensure the safe operation of the Model GF868, it must be installed and operated as described in this manual. In addition, be sure to follow all applicable local safety codes and regulations for the installation of electrical equipment.

## 3.2 Powering Up

Because the Model GF868 does not have an ON/OFF switch, it will power up as soon as the connected power source is energized.

**Note:** For compliance with the European Union's Low Voltage Directive, this unit requires an external power disconnect device such as a switch or circuit breaker. The disconnect device must be marked as such, clearly visible, directly accessible, and located within 1.8 m (6 ft) of the Model GF868. The power cord is the main disconnect device.

Immediately upon power up, the Model GF868 displays "Panametrics" and the software version in the left pane of the display window. The Model GF868 performs a series of internal checks and display the results in the right pane of the display window.

**Note:** If the Model GF868 fails any of the internal checks, try disconnecting the power and then re-powering the unit. If the Model GF868 continues to fail any of the internal checks, contact the factory for assistance.

After successfully performing the internal checks, the Model GF868 begins taking measurements. The power up display is replaced by a measurement mode display similar to that shown in Figure 12.

**Note:** As a minimum, the system and pipe parameters (for each installed channel of a 2-channel meter) must be entered before the Model GF868 can display valid data. Refer to Chapter 2, Initial Setup, for specific instructions.

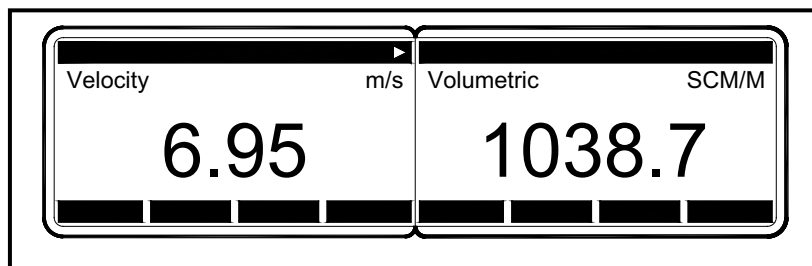

**Figure 12: A Typical Measurement Display**

Proceed to the next section for a description of the components of the Model GF868 display screen.



### 3.3 Using the Display

The Model GF868 display is divided into a left pane and a right pane. The two screen panes can be set independently to display any of the available measurement or diagnostic parameters. The components of a typical measurement mode screen are shown in Figure 13.

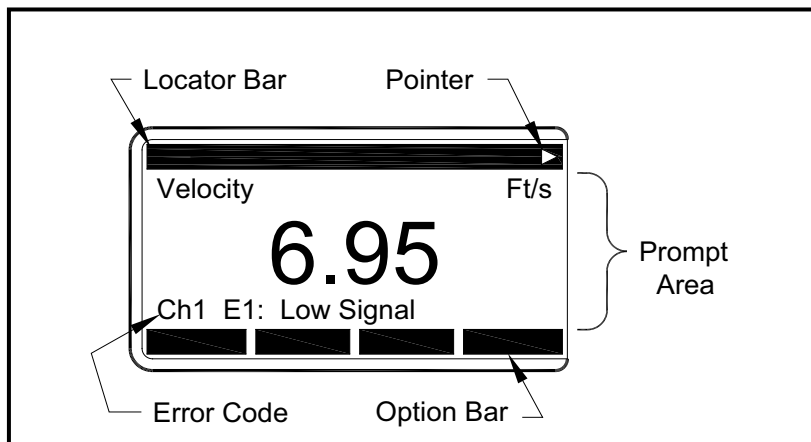

**Figure 13: Display Screen Components**

Both panes of the display screen are continuously updated, but only one pane at a time may be programmed or changed. To select a pane, press the corresponding side of the **[SCREEN]** key on the keypad. The currently selected screen pane will have function names in the option bar, while the other screen pane will have a blank option bar. See the *Programming Manual* for detailed instructions on using the keypad.

As shown in Figure 13, each pane of the display screen is divided into the following three general areas:

- the locator bar
- the prompt area
- the option bar.

The upper portion of the screen pane is called the *locator bar*. While the meter is taking measurements, the locator bar displays the name of the currently selected site file. In addition, the locator bar identifies the task that is currently being performed and the status of that task. For example, pressing the **[PROG]** key on the keypad will cause the locator bar to display **"PROGRAM"** and **"Start"** to indicate that the meter is ready to be programmed from the start of the *User Program*.

### 3.3 Using the Display (cont.)

At various times, one or more of the following four symbols may be displayed on the far right of the locator bar:

- : This symbol, which is called the *pointer*, indicates that additional option bar entries are available. These options can be accessed by using the [←] and [→] keys.
- \*: A flashing asterisk indicates that the Model GF868 is currently logging information. See the *Programming Manual* for instructions on creating a log file.
- S or S<sub>L</sub>: This symbol indicates the status of the red [SHIFT] key. “S” indicates that the [SHIFT] key is activated for the next keystroke only, while “S<sub>L</sub>” indicates that the [SHIFT] key is locked. See the next section for instructions on using the keypad.
- T: This symbol indicates that the Model GF868 is currently totalizing data.

The middle portion of the screen pane is the *prompt area*. This area displays data, graphs, and logs in measurement mode and menu prompts in programming mode. In addition, error code messages, which are described in the *Service Manual*, are displayed in the prompt area.

The lower portion of the screen pane is called the *option bar*. The option bar displays the functions assigned to the four keys immediately below the display screen ([F1]-[F4] for the left pane and [F5]-[F8] for the right pane). Press a function key to select the function listed in the option bar immediately above it. If more than four functions are available, a pointer () appears on the far right of the locator bar. Press the [←] or [→] keys to display the additional functions on the option bar.

For information about other symbols and text that may appear on the display screen, refer to the *Service Manual*.

### 3.4 Taking Measurements

The Model GF868 is capable of displaying several different variables in a variety of formats. However, this manual will only discuss the basic measurement displays in the default screen format. Refer to the *Programming Manual* for instructions on setting up alternate screen displays and see the *Service Manual* for a discussion of the diagnostic parameters listed under the **DIAG** option.

**Note:** This section assumes that the left pane of the display screen is currently active. However, the same instructions apply equally to the right screen pane, when it is active. Just change the function keys from **[F1]-[F4]** to **[F5]-[F8]**.

For a 2-channel Model GF868, the following initial screen appears immediately upon completion of the internal checks. As an example, the display shows the measured velocity in ft/sec for Channel 1.

Ch1 Channel Label	gSITE	To select a different channel display option, press <b>[F1]-[F4]</b> (or <b>[←]</b> and <b>[F1]</b> ). See Table 7 for a complete description of the available options.	
Ch1 Velocity Ft/s			
<b>6.95</b>			
(error codes appear here)			
CH1	CH2	SUM	DIF

**Table 7: Channel Display Options**

Option Bar Choice	Description
<b>[F1] = CH1</b>	Channel 1
<b>[F2] = CH2</b>	Channel 2
<b>[F3] = SUM</b>	(Channel 1) + (Channel 2)
<b>[F4] = DIF</b>	(Channel 1) - (Channel 2)
<b>[→] + [F1] = AVE</b>	[(Channel 1) + (Channel 2)]/2

The following screen appears after selection of the channel mode display option for a 2-channel Model GF868 or immediately after the internal checks for a 1-channel Model GF868.

Ch1) label	gSITE	Use the <b>[F1]-[F4]</b> , <b>[←]</b> and <b>[→]</b> keys to select the desired display parameter option. See Table 8 on page 36 for a complete description of the available options.	
(Ch1) Velocity Ft/s			
<b>6.95</b>			
(error codes appear here)			
VEL	VOLU	+TOT	-TOTL

Ch1 (or Ch2), which is shown in parentheses above, appears only with a 2-Channel Model GF868.

## 3.4 Taking Measurements (cont.)

**Table 8: Measurement Parameter Options**

Option Bar Choice	Description
[F1] = VEL	Flow Velocity
[F2] = VOLUM	Volumetric Flow
[F3] = +TOTL	Forward Totalized Volume Flow
[F4] = -TOTL	Reverse Totalized Volume Flow
[→] + [F1] = TIME	Total Flow Measurement Time
[→] + [F2] = MDOT*	Mass Flow
[→] + [F3] = +MASS*	Forward Totalized Mass Flow
[→] + [F4] = -MASS*	Reverse Totalized Mass Flow
[→] + [→] + [F1] = DIAG	Diagnostic
* Available only if <b>Mass Flow (static)? = YES</b>	

By following the instructions in this section, the Model GF868 can be set up to display the desired channel option (for a 2-Channel meter) and the desired measurement parameter. To utilize the more advanced display capabilities of the Model GF868, refer to the *Programming Manual* and/or the *Service Manual* for the instrument.

### 3.4.1 Foundation Fieldbus Communications

Foundation Fieldbus provides a means of communicating with the flowmeter. The patent numbers which apply are 5,909,363 and 6,424,872.

This Foundation Fieldbus device supports six Analog Input (AI) blocks, which can be configured to supply the following measurements on the network (see Table 9 on page 37).

### 3.4.1 Foundation Fieldbus Communications (cont.)

**Table 9: Measurement Parameter Options Using a Foundation Fieldbus Device**

Channel 1	Units	Channel 2	Units	Average	Units
Ch1 Velocity	ft/s or m/s*	Ch2 Velocity	ft/s or m/s*	Avg Velocity	ft/s or m/s*
Ch1 Act Volumetric	VOL_U	Ch2 Act Volumetric	VOL_U	Avg Act Volumetric	VOL_U
Ch1 Std Volumetric	VOL_U	Ch2 Std Volumetric	VOL_U	Avg Std Volumetric	VOL_U
Ch1 Fwd Totals	TOT_U	Ch2 Fwd Totals	TOT_U	Avg Fwd Totals	TOT_U
Ch1 Rev Totals	TOT_U	Ch2 Rev Totals	TOT_U	Avg Rev Totals	TOT_U
Ch1 #Tot Digits**	none	Ch2 #Tot Digits**	none	Avg #Tot Digits**	none
Ch1 Mass Flow	MASS_U	Ch2 Mass Flow	MASS_U	Avg Mass Flow	MASS_U
Ch1 Fwd Mass Totals	MTOT_U	Ch2 Fwd Mass Totals	MTOT_U	Avg Fwd Mass Totals	MTOT_U
Ch1 Rev Mass Totals	MTOT_U	Ch2 Rev Mass Totals	MTOT_U	Avg Rev Mass Totals	MTOT_U
Ch1 #Mass Tot Digits	none	Ch2 #Mass Tot Digits	none	Avg #Mass Tot Digits	none
Ch1 Timer	sec	Ch2 Timer	sec	Avg Timer	sec
Ch1 Error Code	none	Ch2 Error Code	none	Avg Error Code	none
Ch1 SSUP	none	Ch2 SSUP	none	Avg SSUP	none
Ch1 SSDN	none	Ch2 SSDN	none	Avg SSDN	none
Ch1 Sound Speed	ft/s or m/s*	Ch2 Sound Speed	ft/s or m/s*	Avg Sound Speed	ft/s or m/s*
Ch1 Density***	see note	Ch2 Density***	see note		
Ch1 Temperature	Deg F or C*	Ch2 Temperature	Deg F or C*		
Ch1 Pressure	PRESS_U	Ch2 Pressure	PRESS_U		

\*Metric or English units are determined by the setup of the flowmeter.

\*\*Totalizer digits are available for informational purposes only. Respective totals are automatically scaled by the Tot Digits value selected in the flowmeter setup.

\*\*\*If the meter is outputting Mole Weight, the unit is "mw", otherwise it is the programmed pressure unit.

VOL\_U, TOT\_U, MASS\_U, MTOT\_U and PRESS\_U are determined by the units chosen for these measurements in the flowmeter setup. See the instrument User's Manual for the setup of these parameters.

[no content intended for this page]

## Chapter 4. Specifications

### 4.1 General Specifications

The general specifications for the Model GF868 flowmeter are divided into the following categories:

#### 4.1.1 Hardware Configuration

**Package Options:**

- Epoxy-coated aluminum (standard)
- Stainless steel (optional)
- Fiberglass (optional)
- Explosion-proof (optional)
- Flameproof (optional)

**Physical:** (Epoxy-coated aluminum package)

- Size: 14.24 × 11.4 × 5.12 in. (36.2 × 29 × 13 cm)
- Weight: 11 lb (5 kg)

#### 4.1.2 Environmental

**Operating Temperature:**

- 4° to 131°F (-20° to 55°C)

**Storage Temperature:**

- 67° to 167°F (-55° to 75°C)

#### 4.1.3 Flow Accuracy (% of Reading)

Velocity Accuracy:

**1-Path Measurement**

- ±2% to 5% of reading at ±1 to ±275 ft/s (±0.3 to ±85 m/s)

**2-Path Measurement**

- ±1.4% to 3.5% of reading at ±1 to ±275 ft/s (±0.3 to ±85 m/s)

**Note:** Specifications assume a fully developed flow profile. This is installation-dependent and may require a straight run of pipe 20 diameters upstream and 10 diameters downstream. Accuracy depends on whether measurement is 1- or 2-path.

#### 4.1.4 Range

**Bi-directional:**

- 275 to -0.1 ft/s (-85 to -0.03 m/s)
- +0.1 to 275 ft/s (0.03 to 85 m/s)

### 4.1.5 Molecular Weight and Mass Flow Accuracy (% of Reading)

**Molecular Weight** (hydrocarbon mixtures):

MW 2 to 120 g/mol.

1.8%, optimizable for other gas composition

**Mass Flow** (hydrocarbon mixtures, typical):

1-path: 3 to 7%

2-path: 2.4 to 5%

**Note:** *Dependent on accuracy of temperature and pressure inputs.*

### 4.1.6 Rangeability

2750:1

### 4.1.7 Repeatability

±1% at 0.5 to 100 ft/s (15 cm/s to 30 m/s)

## 4.2 Electrical Specifications

### 4.2.1 Power Supply

**Input Options:**

100 to 130 VAC, 50/60 Hz with 1.0 A Slo-Blo Fuse

200 to 265 VAC, 50/60 Hz with 0.5 A Slo-Blo Fuse

12 to 28 VDC with 3.0 A Slo-Blo Fuse

### 4.2.2 Power Usage

20 W maximum

### 4.2.3 Protection

Built-in mains power surge/lightning protection.

### 4.2.4 European Compliance

This unit complies with EMC Directive 2004/108/EC and 2006/95/EC Low Voltage Directive (Installation Category II, Pollution Degree 2), and PED 97/23/EC for DN<25.



## 4.25 Input/Output Specifications

### Keypad:

39-key membrane keypad with tactile feedback

### Display:

Two independent software-configurable 64 x 128-pixel LCD graphic displays

### Printer/Terminal Communications:

One RS-232 port for printer, terminal, PC, SCADA, etc.

### Standard Inputs:

Two isolated 4 to 20 mA inputs (121  $\Omega$  load) with integral 24 VDC power supply

**Note:** *These inputs are required for temperature and pressure inputs.*

### Standard Outputs

Six 4-20 mA outputs, software assignable

Two outputs for 550 ohm maximum load

Four outputs for 1000 ohm maximum load.

### Measurements

(assignable to any output):

Velocity: 0 to 275 ft/s (0 to 85 m/s)

Volumetric flow rate: standard or actual

Molecular weight: 2 to 120 g/mol

Sound speed: 500 to 5000 ft/s (150 to 1500 m/s)

Mass flow rate: 0 to 4,000,000 lb/h (0 to 2,000,000 kg/h)

### Analog Input Options:

Select up to 3 boards from one of the following types:

1. *Transmitter Input Board* with two isolated 0/4-20 mA inputs and 24-V loop power.
2. *RTD Input Board* with two isolated 3-wire RTD inputs; Span  $-148^{\circ}$  to  $662^{\circ}$ F ( $-100^{\circ}$  to  $350^{\circ}$ C)

### Analog Output Options:

Select up to 3 additional output boards, each with four isolated 4–20 mA outputs (1000  $\Omega$  maximum load).

Digital Interfaces:

Standard: RS232

Optional: RS485 (multiuser)  
RS485 (MODBUS)

HART

Ethernet TCP/IP

MODBUS TCP/IP (Ethernet)

## 4.2.5 Input/Output Specifications (cont.)

### Totalizer/Frequency Output Options:

Select up to 3 Totalizer/Frequency Output Boards, each with four outputs per board, 10 kHz max.

All boards allow software-selectable functioning in two modes:

*Totalizer Mode:* one pulse per defined unit of parameter (e.g., 1 pulse/SCF).

*Frequency Mode:* 5-volt frequency proportional to magnitude of parameter (e.g., 10 Hz = 1 SCFM).

Alarm Options:

Select up to 2 boards of one of the following types:

*Standard Relay Board* with three non-hermetic Form-C relays.

*Hermetic Relay Board* with three hermetically sealed Form-C relays.

## 4.3 Operational Specifications

### 4.3.1 Flow Computer (Built-in)

Programmable from the keypad. Calculates velocity, instantaneous average molecular weight, mass flow rate, and other flow parameters in real time, while simultaneously handling other activities such as programming, logging, calibration, and output of data and diagnostics.

New and improved MW algorithm, now based on temperature and pressure correction of sound speed. Gives wider range, higher accuracy, and improved compensation for non-hydrocarbon gases such as CO<sub>2</sub>, H<sub>2</sub>, N<sub>2</sub>, and CO.

### 4.3.2 Data Logging

Keypad-programmable for setting up log units, update interval, start and stop times. Memory capacity for more than 43,000 data points in a linear or circular log for standard and error logs.

### 4.3.3 Display Functions

Graphic display shows flow in numeric or graphic format. Also displays logged data and diagnostics.

### 4.3.4 Printer Signal Output

Supports wide variety of thermal and impact printers. Output data in numeric or graphic ("strip chart") format.

## 4.4 Transducer/Flowcell Specifications

### 4.4.1 Transducer Type

Standard Panametrics type T5 (welded assembly of Ti transducer). For agency certifications, contact the factory.

### 4.4.2 Temperature Range

Standard: -94° to +300°F (-70° to 150°C)

Optional high temperature: -94° to +536°F (-70° to +280°C)

Optional low temperature: -364° to +248°F (-220° to +120°C)

### 4.4.3 Pressure Range

0 to 1500 psig (1 to 1.5 bar)

### 4.4.4 Materials

Standard: Titanium

Optional: Monel<sup>®</sup>, Hastalloy<sup>®</sup>, and 316 stainless steel

### 4.4.5 Connections

#### Cable Length:

Up to 1000 ft (300 m)

#### Housing Options:

Explosion-proof (Type-7, Class I, Group C & D, Division I.)

Weatherproof (Type-4X, IP65)

Flameproof (Ex II 2 G EEx d II C T6)

### 4.4.6 Mounting and Installation

Mechanical insertion mechanism rated to 500°F and 500 psig.

## **4.5 Flowcell Specifications**

### **4.5.1 Spoolpiece**

Prefabricated spools complete with transducer/mechanism port:  
Pipe sizes: 3 to 120 in.  
Process Connections: Plain end; 150, 300, or 600 lb. RF flanged.  
Materials: carbon steel, low-carbon steel, stainless steel, or other.

### **4.5.2 Hot/Cold Tap**

Mechanisms installed via hot or cold tap. Full installation jigs, fittings, and documentation provided.

Process Connections: NA

### **4.5.3 Preamplifier with Explosion-proof Housing**

Operating Temperature: -40° to +140° (-40° to +60°C)

## Appendix A. CE Mark Compliance

### A.1 Introduction

For CE Mark compliance, the Model GF868 flowmeter must be wired in accordance with the instructions in this appendix.

**IMPORTANT:** CE Mark compliance is required only for units intended for use in EC countries.

### A.2 Wiring

The Model GF868 must be wired with the recommended cable, and all connections must be properly shielded and grounded. Refer to Table 10 for the specific requirements.

**Table 10: Wiring Modifications**

Connection	Cable Type	Termination Modification
Transducer	RG62 a/u	Add metallic cable clamp from braid to chassis gnd.
	Armored RG62 a/u or conduit	None - grounded via cable gland.
Input/Output	22 AWG shielded (e.g. Baystate #78-1197)	Terminate shield to chassis ground.
	Armored conduit	None - grounded via cable gland.
Power	14 AWG, 3 conductor, shielded (e.g. Belden #19364)	An external ground to the chassis is required.
	Armored Conduit	None - grounded via cable gland.
Shielding	For CE compliance, power and I/O cables must be shielded. Cables to be terminated within cable gland at the GF868. Shielded cable is not required when installations include metal conduit.	

### A.3 External Grounding

For CE Mark compliance, the electronics enclosure and the transducer fixture must each have an external ground wire attached.

**Note:** If the Model GF868 is wired as described in this appendix, the unit will comply with the EMC Directive 2004/108/EC.

[no content intended for this page]

## Appendix B. Data Records

### B.1 Option Cards Installed

Whenever an option card is installed in one of the Model GF868's expansion slots, record the type of card and any additional setup information in the appropriate row of Table 11.

**Table 11: Option Cards Installed**

Slot #	Type of Option Card	Additional Setup Information
0	Analog Outputs (A, B)	
1		
2		
3		
4		
5		

## B.2 Initial Setup Data

After the Model GF868 flowmeter has been installed, some initial setup data must be entered via the *User Program*, prior to operation. Record that information in Table 12.

**Table 12: Data Information Sheet**

General Information					
Model #			Reference		
Software Vers.			Date		
Serial #			Z Dimension		
Measurement Method (1-Channel) - <i>ACTIV</i>					
Site Status	Burst		Measure Mode	Skam	S/M
Measurement Method (2-Channel) - <i>ACTIV</i>					
Channel 1			Channel 2		
Channel Status	Off	Burst	Channel Status	Off	Burst
Measure Mode	Skam	S/M	Measure Mode	Skam	S/M
System Parameters - <i>SYSTEM</i>					
1-Channel			2-Channel		
Site Label			Chan.1 Label		
Site Message			Chan. 1 Message		
System Units	English	Metric	Chan. 2 Label		
Pressure Units			Chan. 2 Message		
Stopwatch Total.	Auto	Manual			
1-Channel and 2-Channel					
Channel 1			Channel 2 (if applicable)		
Vol. Units			Vol. Units		
Vol. Time Units			Vol. Time Units		
Vol. Dec. Digits			Vol. Dec. Digits		
Totalizer Units			Totalizer Units		
Tot. Dec. Digits			Tot. Dec. Digits		
Mass Flow			Mass Flow		
Mass Flow Time			Mass Flow Time		
MDOT Dec. Dig.			MDOT Dec. Dig.		
Mass Totalizer			Mass Totalizer		
Mass Dec. Dig.			Mass Dec. Dig.		

Pipe/Transducer Parameters - <i>PIPE</i>					
Channel 1			Channel 2 (if applicable)		
Std. Trans. #			Std. Trans. #		
Spec. Trans. #			Spec. Trans. #		
Spec. Trans. Hz			Spec. Trans. Hz		



**Table 12: Data Information Sheet**

Spec. Trans. Tw				Spec. Trans. Tw				
<b>Pipe/Transducer Parameters (cont.) - PIPE</b>								
Channel 1 (cont.)				Channel 2 (cont.)				
Pipe O.D.				Pipe O.D.				
Pipe Wall				Pipe Wall				
Path Length (P)				Path Length (P)				
Axial Length (L)				Axial Length (L)				
Multi K-factors		Off	On	Multi K-factors		Off	On	
Edit Table		No	Yes	Edit Table		No	Yes	
K-factor Table			K-factor Table			K-factor Table		
K-Factor #	Velocity	K-Factor	K-Factor #	Velocity	K-Factor	K-Factor #	Velocity	K-Factor
1			1			1		
2			2			2		
3			3			3		
4			4			4		
5			5			5		
6			6			6		
7			7			7		
8			8			8		
9			9			9		
10			10			10		
11			11			11		
12			12			12		
13			13			13		
14			14			14		
15			15			15		
16			16			16		
17			17			17		
18			18			18		
19			19			19		
20			20			20		

[no content intended for this page]

## Appendix C. Optional Enclosures

### C.1 Introduction

Upon request the Model GF868 flowmeter may be supplied in an enclosure other than the standard Type-4X enclosure described in Chapter 1, *Installation*, of this manual. Although the standard installation and wiring instructions still apply in general terms, some of the details may vary for different enclosure types. Refer to the appropriate sections of this appendix for the specific type of enclosure provided.

### C.2 Rack Mount Enclosure

The Model GF868 flowmeter is available in a *rack mount* enclosure for installation in a standard 19" electronics rack. Refer to Figure 14 on page 53 for the dimensions of this unit. Simply slide the Model GF868 into the rack at the desired height and fasten the unit securely to the rack with four screws in the locations provided at the sides of the front panel.

After the unit has been physically mounted into the rack, proceed to the next section for instructions on wiring the meter.

### C.3 Rack Mount Wiring

The rack mount Model GF868 requires exactly the same electrical connections as the standard version. However, the locations and type of connectors used for the various components are different. Refer to Figure 15 on page 54 and complete the following steps:

1. Wire the *power input* on the right side of the rear panel as follows:
  - a. Make sure a **fuse** (item #4) of the proper size and type is installed.
  - b. Connect the female end of the **line cord** provided to the power input receptacle (item #3).
  - c. Connect the **earth ground** screw terminal (item #2) to a ground point on the rack.
2. Wire the *transducers* as follows:
  - a. Connect the pair of cables supplied with the meter to the **Channel 1** upstream and downstream BNC transducer connectors on the left side of the rear panel.
  - b. For a 2-Channel meter, repeat the above step for the **Channel 2** transducer connectors (if the second channel is to be used).
  - c. Complete the transducer wiring in accordance with the instructions in Chapter 1, *Installation*, of this manual.

## C.0 Rack Mount Wiring (cont.)

4. Wire the 0/4-20 mA *analog outputs* at the left side of the rear panel in accordance with the instructions in Chapter 1, *Installation*, of this manual.
  5. Wire the *RS232 serial port* by completing the following steps:
    - a. Purchase or prepare a suitable serial cable. This cable should have a standard female DB9 connector, wired as shown in Figure 15 on page 54, for connection to the rear panel of the Model GF868. The other end should be as required for the external device.
    - b. Complete the serial port wiring in accordance with the instructions in Chapter 1, *Installation*, of this manual.
  6. Wire any installed *option cards* using the same procedures described in Chapter 1, *Installation*, of this manual and the pin # assignments shown in Figure 15 on page 54.
  7. Place the *power switch* (item #1) in the ON position.
- The Model GF868 is now completely wired. Proceed to Chapter 2, *Initial Setup*, of this manual for further instructions.

## C.1 Rack Mount Front Panel

The keypad and LCD display for the rack mount Model GF868 are located on the front panel. These items are identical in form and function to those used on the standard Type-4X enclosure, but the layout is somewhat different.

Refer to Figure 16 on page 55 for the front panel layout of the rack mount Model GF868 and follow the standard procedures detailed in the main body of this manual.

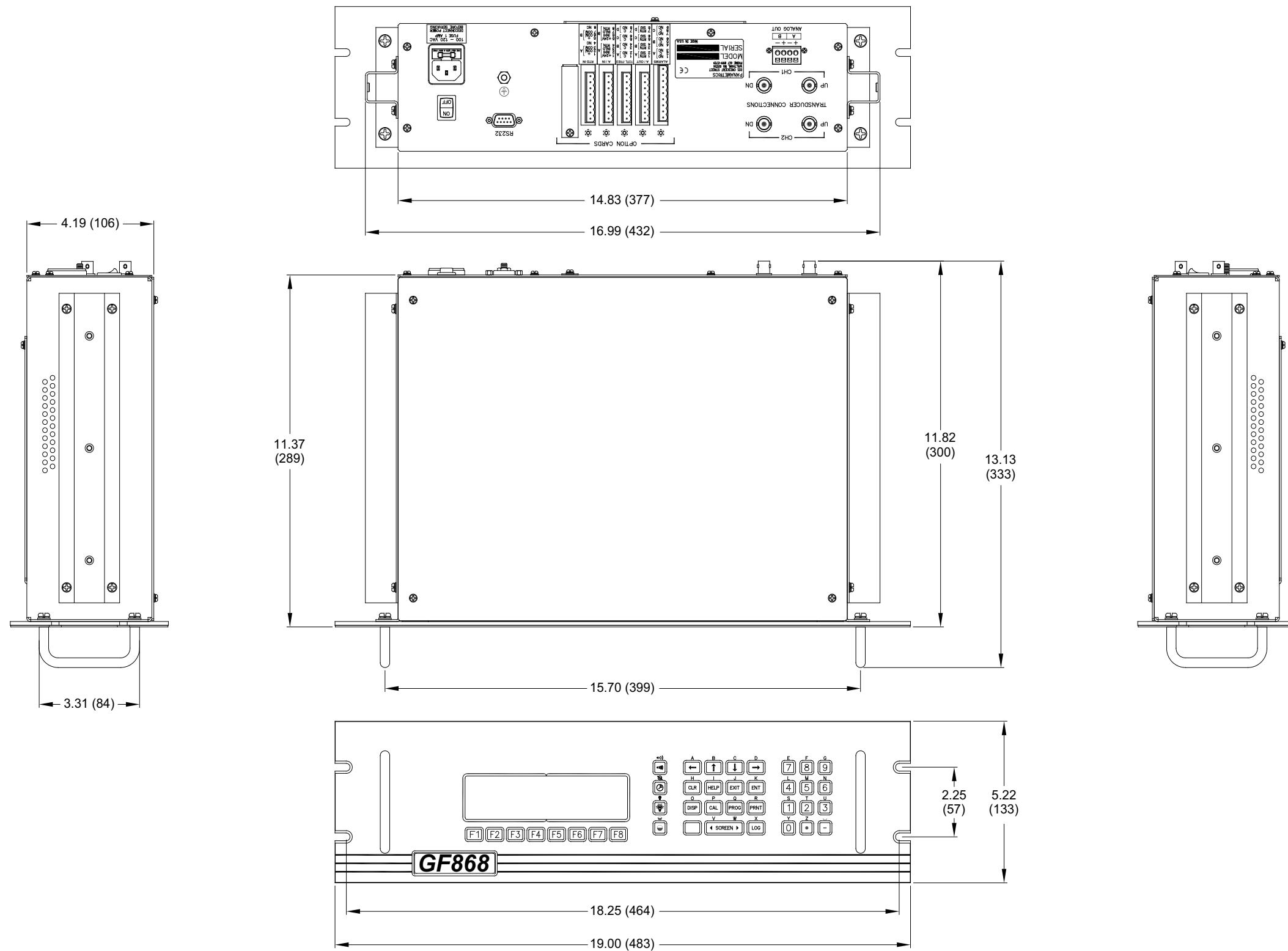

Figure 14: Model GF868 Rack Mount Enclosure (ref. dwg #712-1078)

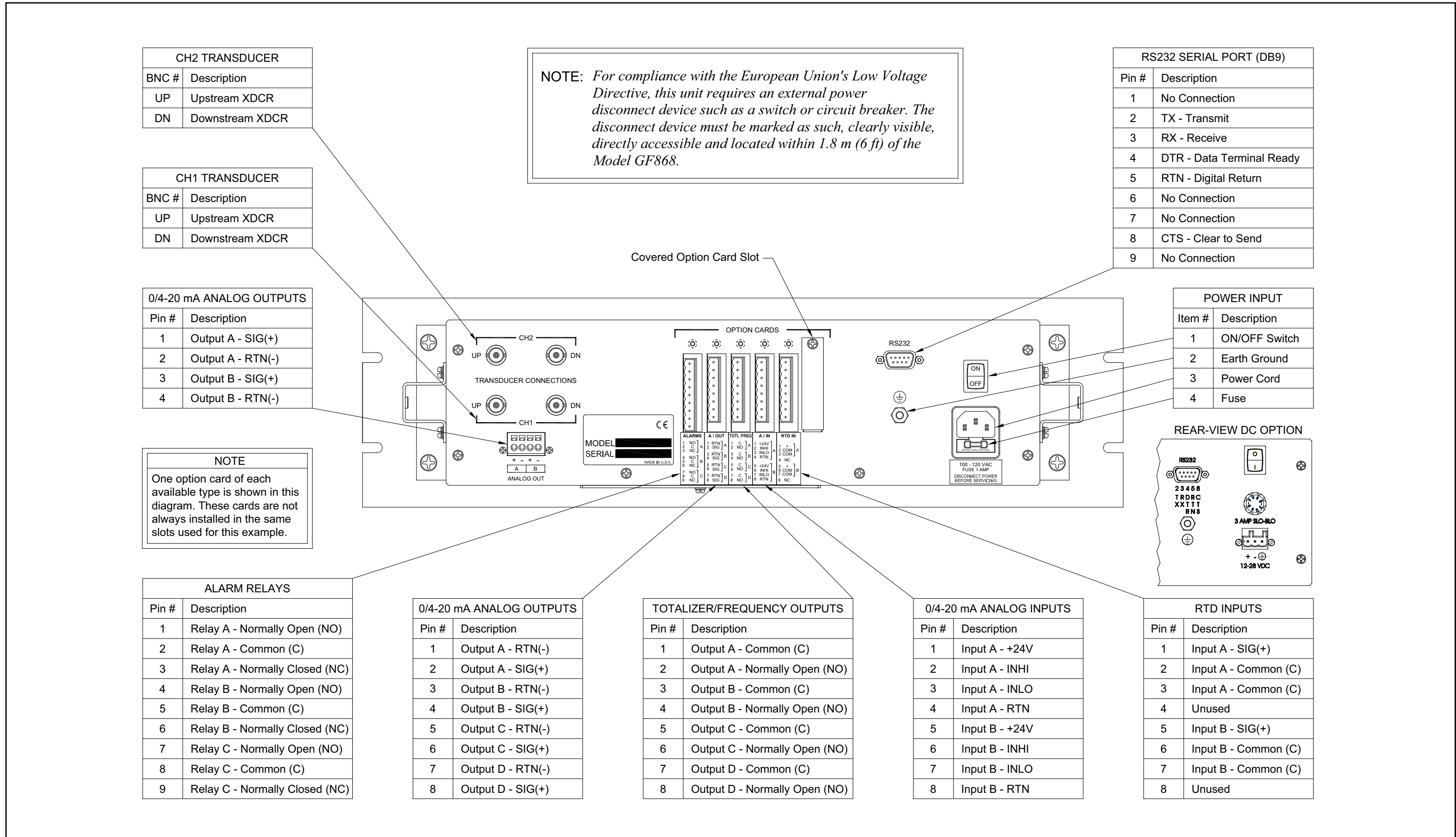

Figure 15: Model GF868 Rack Mount Enclosure - Wiring Diagram

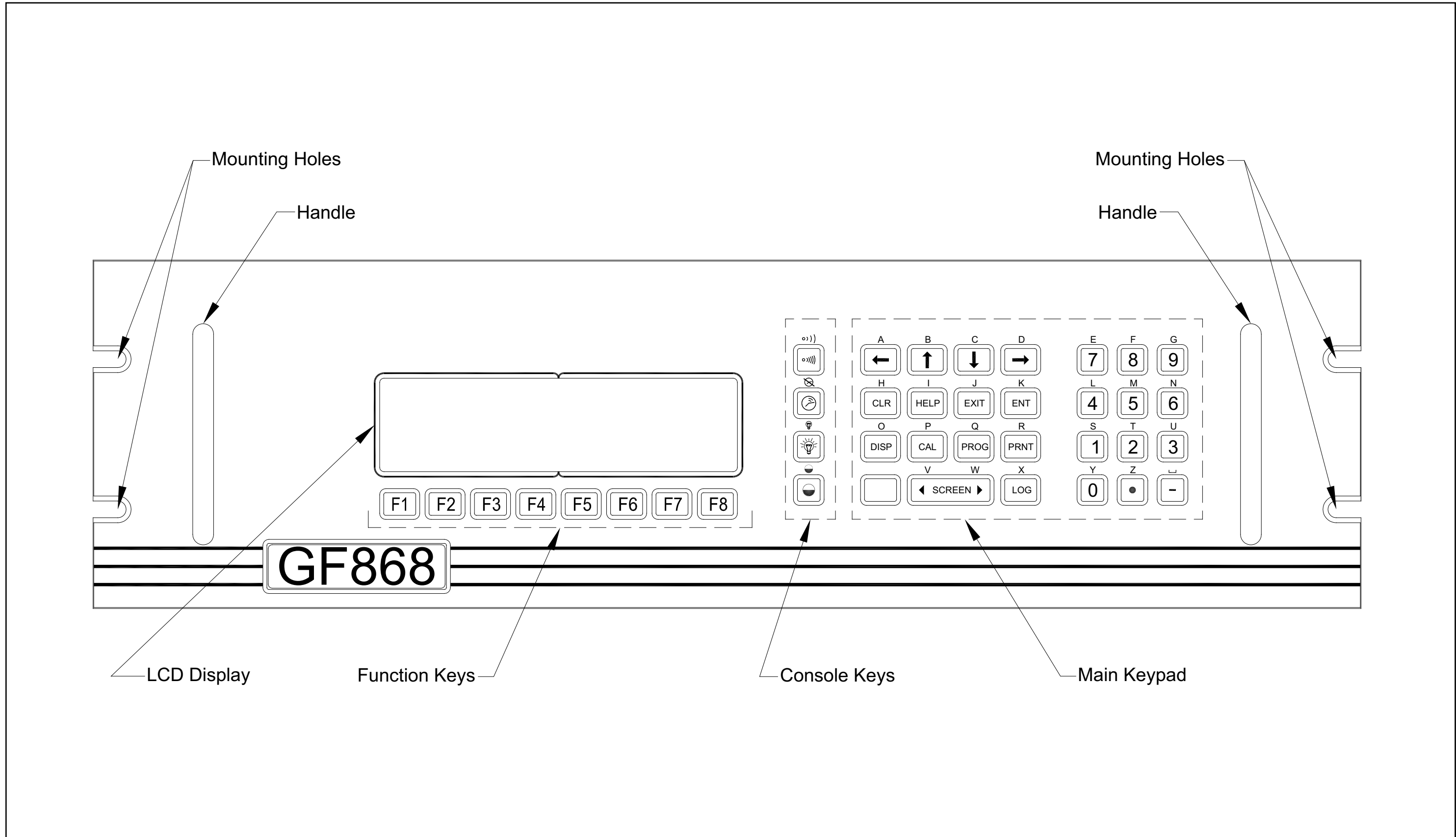

Figure 16: Model GF868 Rack Mount Enclosure - Front Panel Layout





## Appendix D. Measuring P and L Dimensions

### D.1 Introduction

When programming the PIPE menu of the Model GF868's *User Program*, the *path length* (P) and the *axial dimension* (L) must be entered. These parameters are determined by measurements on the actual transducer installation, with P equal to the face-to-face distance between the transducers and L equal to the axial distance between the centers of the transducer faces.

The accuracy of the programmed P and L values is critical to precise flow rate measurements. If Panametrics supplies the flowcell for the system, the correct values will be included in the documentation supplied with the unit. For transducers installed on an existing pipe (see Figure 17 on page 58), P and L must be measured at the site. This appendix provides instructions for properly determining these dimensions.

### D.2 Measuring P and L Distances

Whenever possible, physically measure the face-to-face distance (P) and the axial distance (L) between the centers of the flat faces of the transducers. Refer to Figure 17 on page 58 for an illustration of the proper distances to measure in a typical installation.

In some situations only one of the required distances can be directly measured. When this happens, a knowledge of the installation angle ( $\theta$ ) of the transducers, permits the second distance to be calculated from the equation below:

$$\cos \theta = \frac{L}{P}$$

As an example, assume that the transducer installation angle is known to be  $45^\circ$  and the L distance is measured to be 10.00 inches. Then, the P distance is calculated to be  $P = 10.00/0.707 = 14.14$  inches.

With a Bias  $90^\circ$  transducer installation, it sometimes happens that the only known parameters are the transducer angle ( $\theta$ ) and the centerline distance between the transducer bodies (CL). In these cases, it is still possible to calculate both P and L by combining the first equation above with the second equation below (see Figure 17 on page 58):

$$P = CL - 1.2$$

Standard Panametrics  $90^\circ$  transducers have the face offset from the centerline of the body by 0.6 inches. Thus, a pair of transducers has a total offset of 1.2 inches, as indicated in the second equation. For example, suppose that the transducer installation angle is  $30^\circ$  and CL is measured to be 12.00 inches. Then,  $P = 12.00 - 1.2 = 10.80$  inches and  $L = 10.80 \times 0.866 = 9.35$  inches.

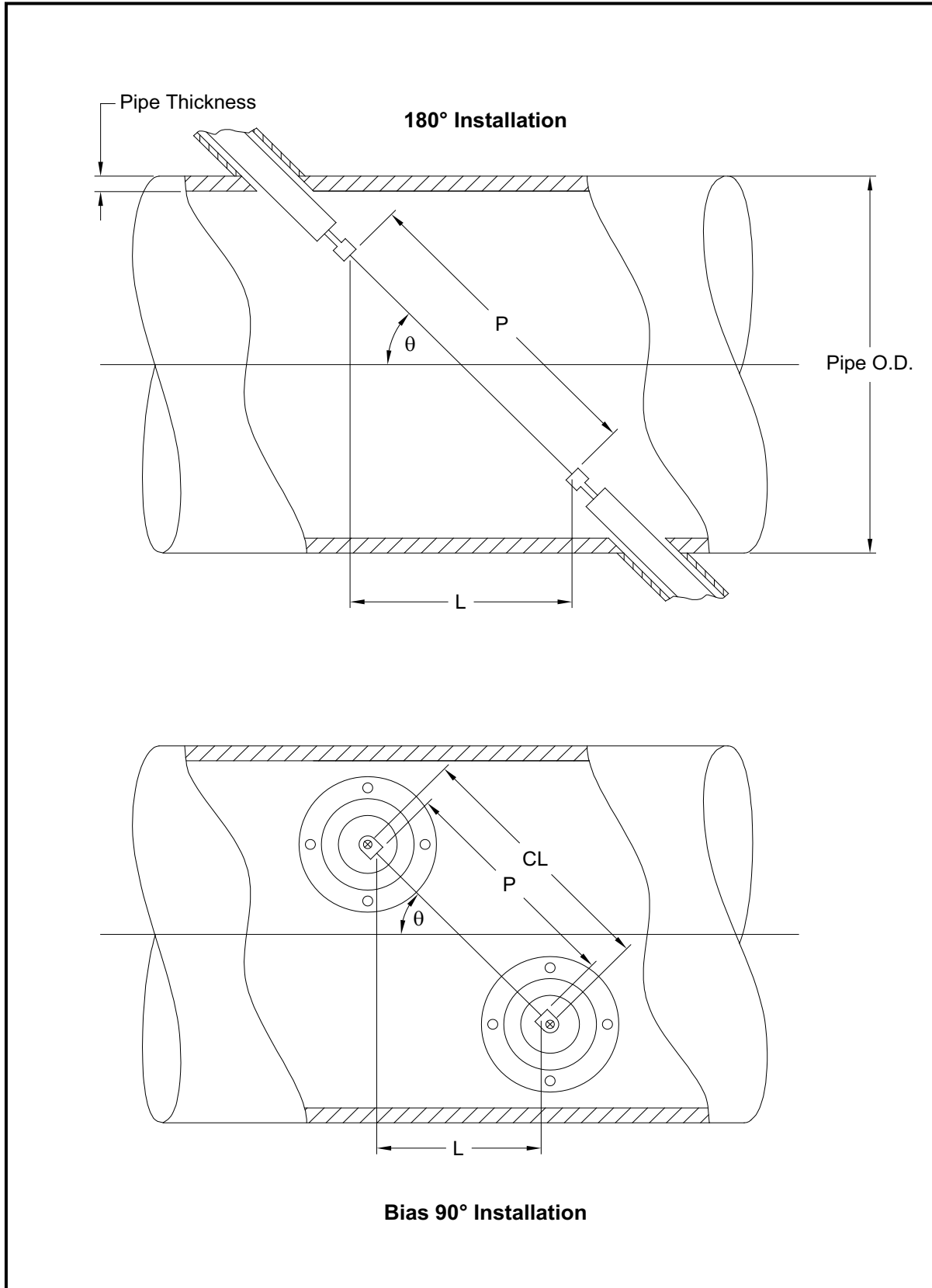

**Figure 17: Top View of Transducer Installations**

<b>A</b>		Measurements	
Abbreviations, Volumetric & Totalizer Units.....	25	Displaying.....	
ACTIV Submenu .....	23	Parameter Options.....	
Alarm Options .....	42	Taking .....	
Analog Inputs Option Card		MODBUS/TCP, Wiring the.....	
Ratings .....	41	Molecular Weight.....	
Axial Dimension.....	57	<b>O</b>	
<b>C</b>		Operating Temperature.....	
CE Mark Compliance.....	45	Option Bar.....	
Configuration, Hardware .....	39	Option Card	
<b>D</b>		Setup Information Table.....	
Data Logging .....	42	<b>P</b>	
Digital Interfaces for GF868 .....	41	Parameter Options.....	
Display		Path Length .....	
Channel Mode Options.....	35	Pipe OD, Available Units.....	
Components.....	33	Pipe OD, Programming .....	
Data .....	32	PIPE Submenu.....	
Locator Bar.....	33	Pointer .....	
Locator Bar Symbols.....	34	Power Supply .....	
Measurement Mode .....	32	Power Usage.....	
Option Bar.....	33	Powering Up	
Parameter Options.....	36	Display.....	
Pointer .....	33	Internal Checks.....	
Prompt Area .....	33	Pressure Range.....	
Selecting .....	33	Printer Signal Output.....	
Using.....	33	Printer/Terminal Communications.....	
Display Functions.....	42	Programming Data	
<b>E</b>		Record.....	
European Compliance of GF868 .....	40	Prompt Area .....	
<b>F</b>		Protection, Electrical .....	
Fieldbus Network .....	12	<b>R</b>	
Connections .....	12	Rack Mount	
Flow Accuracy.....	39	Front Panel.....	
Flow Computer .....	42	Installation .....	
Function Keys .....	34	Wiring.....	
Fuse Ratings .....	40	Range.....	
<b>H</b>		Rangeability .....	
Hardware Configuration .....	39	Repeatability.....	
<b>I</b>		Return Policy.....	
Initial Setup		Reynolds Correction .....	
Data Table .....	48	RS232 Port	
Input/Output Specifications.....	41	See Serial Port	
Installation Instructions for CE Mark Compliance.....	45	<b>S</b>	
Internal Tests .....	32	Screen, Selecting.....	
<b>K</b>		Serial Port	
Kinematic Viscosity .....	28	Connecting .....	
<b>L</b>		Pin Assignments.....	
Locator Bar.....	33		
<b>M</b>			
Mass Flow Accuracy .....	40		
Measurement Outputs .....	41		

## Specifications

Electrical.....	40
General.....	39
Input/Output.....	41
Mass Flow Accuracy.....	40
Molecular Weight.....	40
Operational.....	42
Range.....	39
Rangeability.....	40
Repeatability.....	40
Transducer/Flowcell.....	43
Standard Outputs.....	41
Storage Temperature.....	39
Symbols, Locator Bar.....	34
SYSTEM Submenu.....	24
for 1-Channel Meter.....	24
for 2-Channel Meter.....	25

**T**

Temperature Range.....	43
Terminal Block	
Serial Port - RS232.....	8
Totalizer/Frequency Output Options.....	42
Transducer Connections.....	43
Transducer Materials.....	43
Transducer Mounting and Installation.....	43
Transducer Number, Entering.....	27
Transducer Type.....	43
Transducer/Flowcell Specifications.....	43
Transducers	
180° Installation.....	57
Axial Dimension.....	57
Bias 90° Installation.....	57
Installation Angle.....	57
Path Length.....	57

**W**

Warranty.....	61
Wiring	
CE Mark Compliance.....	45
Foundation Fieldbus.....	12

---

## Warranty

Each instrument manufactured by Panametrics Sensing is warranted to be free from defects in material and workmanship. Liability under this warranty is limited to restoring the instrument to normal operation or replacing the instrument, at the sole discretion of Panametrics Sensing. Fuses and batteries are specifically excluded from any liability. This warranty is effective from the date of delivery to the original purchaser. If Panametrics Sensing determines that the equipment was defective, the warranty period is:

- one year from delivery for electronic or mechanical failures
- one year from delivery for sensor shelf life

If Panametrics Sensing determines that the equipment was damaged by misuse, improper installation, the use of unauthorized replacement parts, or operating conditions outside the guidelines specified by Panametrics Sensing, the repairs are not covered under this warranty.

---

**The warranties set forth herein are exclusive and are in lieu of all other warranties whether statutory, express or implied (including warranties or merchantability and fitness for a particular purpose, and warranties arising from course of dealing or usage or trade).**

---

## Return Policy

If a Panametrics Sensing instrument malfunctions within the warranty period, the following procedure must be completed:

1. Notify Panametrics Sensing, giving full details of the problem, and provide the model number and serial number of the instrument. If the nature of the problem indicates the need for factory service, Panametrics Sensing will issue a RETURN AUTHORIZATION NUMBER (RAN), and shipping instructions for the return of the instrument to a service center will be provided.
2. If Panametrics Sensing instructs you to send your instrument to a service center, it must be shipped prepaid to the authorized repair station indicated in the shipping instructions.
3. Upon receipt, Panametrics Sensing will evaluate the instrument to determine the cause of the malfunction.

Then, one of the following courses of action will then be taken:

- If the damage is covered under the terms of the warranty, the instrument will be repaired at no cost to the owner and returned.
- If Panametrics Sensing determines that the damage is not covered under the terms of the warranty, or if the warranty has expired, an estimate for the cost of the repairs at standard rates will be provided. Upon receipt of the owner's approval to proceed, the instrument will be repaired and returned.

[no content intended for this page]

---

## Panometrics Infrastructure Products Used in Hazardous Locations

Installation and operation manuals in their complete forms, along with product specific certification and safety statement sheets are included on the CD provided with the product documentation shipped with each instrument. Please read and follow all provided manufacturer's instructions prior to installation and the application of power to your equipment. Always observe the following:

- Field wiring shall be rated at least 10°C above rated ambient.
- Connecting cables shall be mounted securely and protected from mechanical damage, pulling and twisting.
- Cable entry thread types are identified on the equipment label.
- Cable glands of an approved flameproof design are required for **Ex d** rated equipment. These must be installed according to the manufacturer's instructions. Where the cable glands are provided by Panometrics, the manufacturer's instructions, as supplied to Panometrics, will be included in the documentation.
- Unused cable entries must be sealed using a suitably certified threaded plug.
- Modifications to any flameproof enclosure are not permitted.
- The apparatus must be de-energized before opening, servicing and conducting any routine maintenance.
- Installation shall be in accordance with the installation instructions and the National Electrical Code® ANSI/NFPA 70, the Canadian Electrical Code C22.1, or IEC/EN 60079-14, as applicable.
- The product contains no exposed parts which produce surface temperature infrared, electromagnetic ionizing, or non-electrical dangers.
- The product must not be subjected to mechanical or thermal stresses in excess of those permitted in the certification documentation and the instruction manual.
- The product cannot be repaired by the user. It must be replaced by an equivalent certified product. Repairs should only be carried out by the manufacturer or by an approved repairer.
- Only trained, competent personnel may install, operate and maintain the equipment.
- The product is an electrical apparatus and must be installed in the hazardous area in accordance with the requirements of the *EC Type Examination Certificate*. The installation must be carried out in accordance with all the appropriate international, national and local standard codes and practices and site regulations for flameproof apparatus and in accordance with the instructions contained in the manual. Access to the circuitry must not be made during operation.

---

## Special Conditions for Safe Use

1. Consult the manufacturer if dimensional information on any flameproof joint is necessary.
2. Follow the manufacturer's instructions to reduce the potential of an electrostatic charging hazard.
3. Consult the manufacturer for genuine replacement flange fasteners. M10x35 hexagon socket cap screws of ISO 12.9 DIN912 grade steel (zinc-plated) or better with a minimum yield strength of 135,000 psi are acceptable alternatives.
4. The sensor body temperature code rating is dependent on the process temperature. It is assumed that the external surface of the sensor body will be, at worst case, equal to the process temperature (up to 140°C). In all cases, the electronics assembly will be marked **T6** as it will be locally mounted for process temperatures up to 85°C and will be remotely mounted for process temperatures exceeding 85°C.

## Markings

Markings appear on the instrument label which identifies the product model, serial number, operating ranges, hazardous area ratings, entry thread type, and warning and caution information.

## EU / EEA Installation Compliance

The use of this apparatus is subject to the EU directive on minimum requirements for improving the safety and health protection of workers potentially at risk from explosive atmospheres, **Council Directive 1999/92/EC**. The installer is required to be familiar with this document or the National transposing legislation.

## Increased Safety Wiring Connections

### Power Connection:

Maximum Size †:	Solid - 4.0 mm <sup>2</sup> (12 AWG)
	Stranded - 2.5 mm <sup>2</sup> (14 AWG)
Number of conductors †:	2 Solid - max 1.5mm <sup>2</sup> (16 AWG)
	2 Stranded - max 1.0 mm <sup>2</sup> (18 AWG)

### All Other Screw Terminal Connections:

Maximum Size †:	Solid - 4.0 mm <sup>2</sup> (12 AWG)
	Stranded - 2.5 mm <sup>2</sup> (14 AWG)
Number of conductors †:	2 Solid - max 1.5mm <sup>2</sup> (16 AWG)
	2 Stranded - max 1.0 mm <sup>2</sup> (18 AWG)

‡ - Single conductor

† - Multi-conductors of same cross-section



---

We,

**Panametrics Sensing  
1100 Technology Park Drive  
Billerica, MA 01821  
USA**

**declare under our sole responsibility that the**

**DigitalFlow™ DF8688 Liquid Ultrasonic Flowmeter  
DigitalFlow™ GC868 Clamp-On Gas Ultrasonic Flowmeter  
DigitalFlow™ GF868 Flare Gas Mass Ultrasonic Flowmeter  
DigitalFlow™ GM868 General-Purpose Gas Ultrasonic Flowmeter  
DigitalFlow™ GS868 Steam Mass Ultrasonic Flowmeter**

to which this declaration relates, are in conformity with the following standards:

- EN 60079-0: 2009
- EN 60079-1: 2007
- EN60529: 1991 + A1: 2000
- II 2 G Ex d IIB+H2 T6 Gb Ta = 20°C to 60°C; IP66; FM12ATEX0040X  
(FM Approvals Ltd, Windsor, Berkshire, UK - NoBo 1725)
- EN 61326-1: 2006, Class A, Table 2, Industrial Locations
- EN 61326-2-3: 2006
- EN 61010-1: 2012, Overvoltage Category II

following the provisions of the 2004/108/EC EMC, 2006/95/EC Low Voltage and 94/9/EC ATEX Directives.

The unit listed above and any ancillary equipment supplied with it do not bear CE marking for the Pressure Equipment Directive, as they are supplied in accordance with Article 3, Section 3 (sound engineering practices and codes of good workmanship) of the Pressure Equipment Directive 97/23/EC for DN100.



**Billerica - February 12, 2015**

**Issued**

---

**Mr. Gary Kozinski  
Certification & Standards, Lead Engineer**

---

[no content intended for this page]



## Customer Support Centers

### U.S.A.

The Boston Center  
1100 Technology Park Drive  
Billerica, MA 01821  
U.S.A.  
Tel: 800 833 9438 (toll-free)  
978 437 1000  
E-mail: [mstechsupport@bakerhughes.com](mailto:mstechsupport@bakerhughes.com)

### Ireland

Sensing House  
Shannon Free Zone East  
Shannon, County Clare  
Ireland  
Tel: +353 (0)61 470200  
E-mail: [mstechsupport@bakerhughes.com](mailto:mstechsupport@bakerhughes.com)

Copyright 2021 Baker Hughes company.

This material contains one or more registered trademarks of Baker Hughes Company and its subsidiaries in one or more countries. All third-party product and company names are trademarks of their respective holders.

BH015C33 EN F (07/2021)

**Baker Hughes** 