

## LMS100PB+

The best simple-cycle efficiency gas turbine

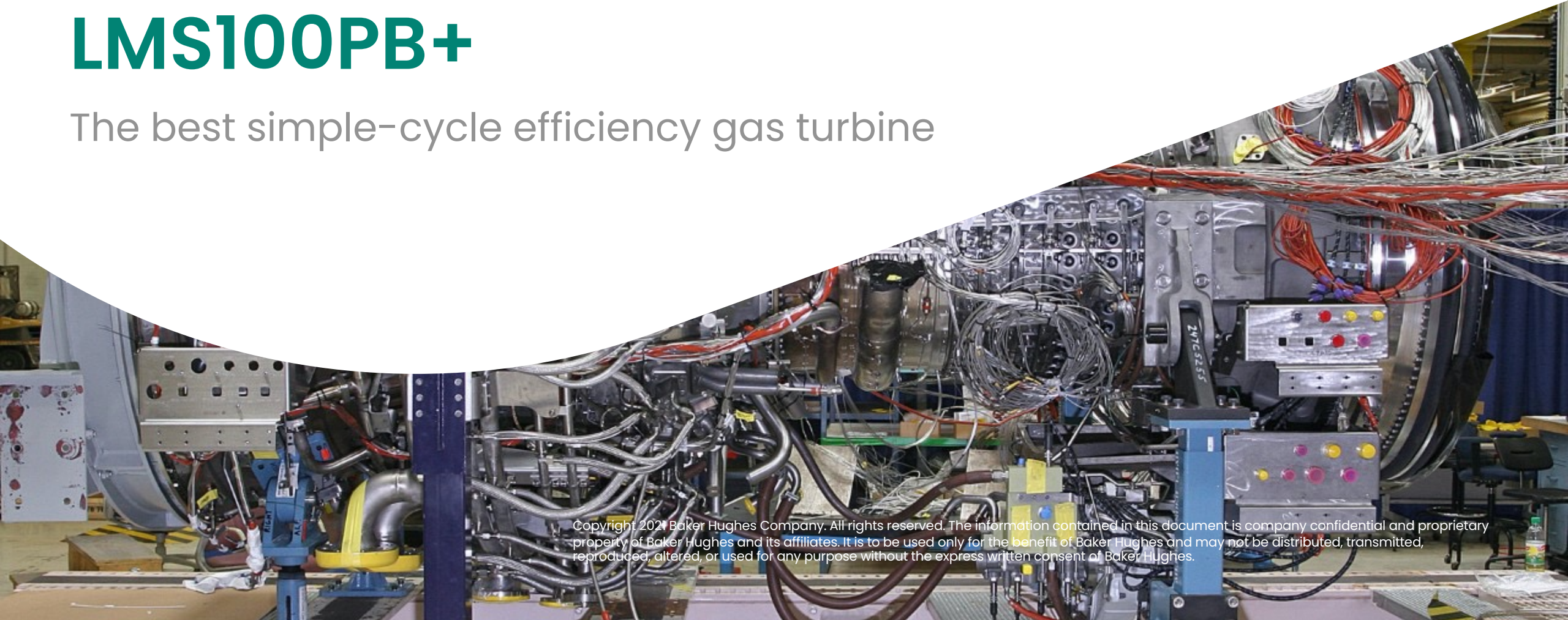

Copyright 2021 Baker Hughes Company. All rights reserved. The information contained in this document is company confidential and proprietary property of Baker Hughes and its affiliates. It is to be used only for the benefit of Baker Hughes and may not be distributed, transmitted, reproduced, altered, or used for any purpose without the express written consent of Baker Hughes.

# Industry leader in gas turbine technology

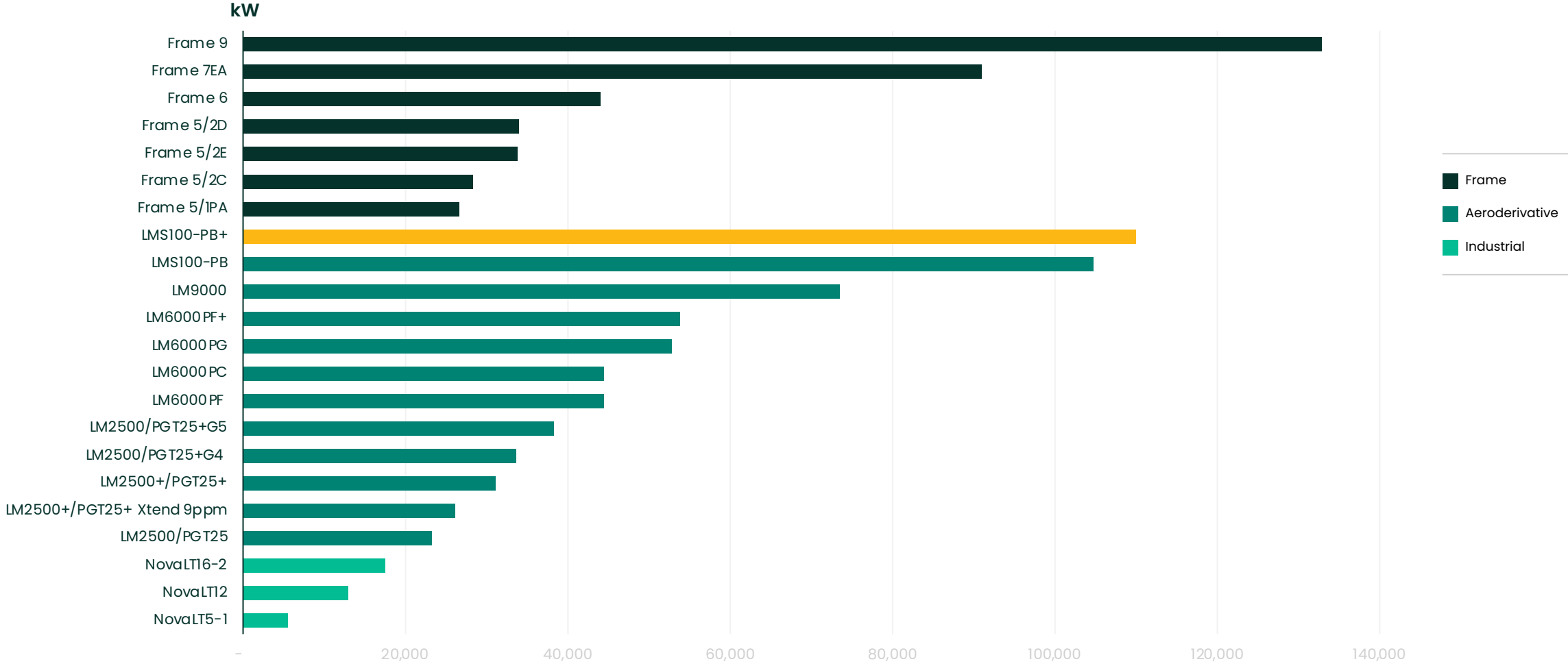

# LMS100PB+

Best simple-cycle efficiency  
for lowest CO<sub>2</sub> emissions

The LMS100 is the only modern industrial gas turbine with an intercooling system between the low-pressure compressor (LPC) and the high-pressure compressor (HPC). This reduces the compression work by 30% (at parity of pressure ratio) versus a conventional cycle delivering best-in-class simple-cycle efficiency (>44%) and minimum CO<sub>2</sub> emissions.

The free power turbine (aerodynamically coupled with the supercore but mechanically independent) makes the LMS100 engine suitable for both mechanical drive and generator drive applications—with no need of a gearbox. It also permits pressurized start-ups in LNG plants without a helper motor.

The LMS100 design is largely based on proven technology, mixing heavy-duty (LPC and PT assembly) and aeroderivative (supercore: core + IPT) components

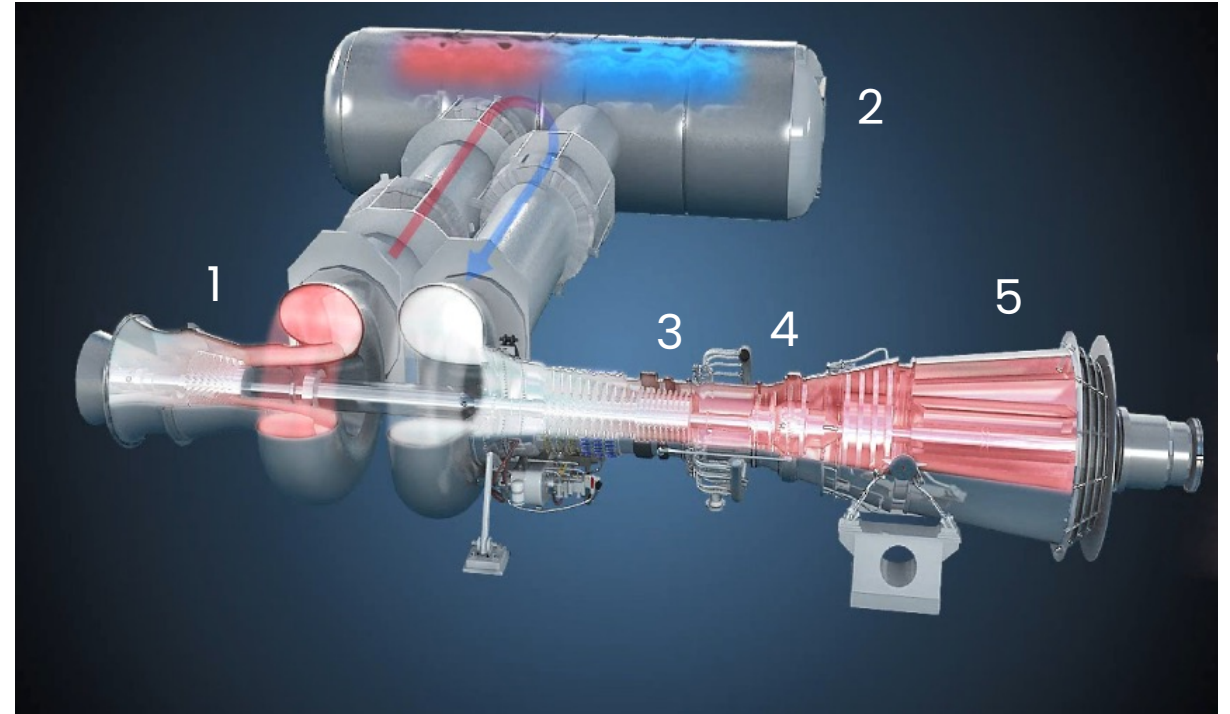

1. LPC derived from the first 6 stages of the compressor of the heavy-duty Frame 6FA gas turbine
2. Intercooler
3. Core section (HPC, turbine, and combustion system) in common with the LM6000 aeroderivative engine
4. Intermediate-pressure turbine (IPT) driving the LPC
5. Free power turbine (PT)

# Package

LMS100PB+ package is a perfect mechanical-drive solution to maximize economies of scale for LNG liquefaction trains.

Its three-shaft architecture enables both for 50 and 60 Hz power generation/CHP.

Start-up in less than 10 minutes makes it ideal for integration with renewable energy systems.

The package has been specifically designed to satisfy oil and gas applications requirements:

- Classified for Hazardous Area Zone 2 Class T3, Gas Group IIB
- Compliant with winterization and marinization requirements
- Implemented TMR instrument configuration (triple redundancy)
- Gas turbine installed on a single skid
- Key components from the legacy GTG package have been maintained

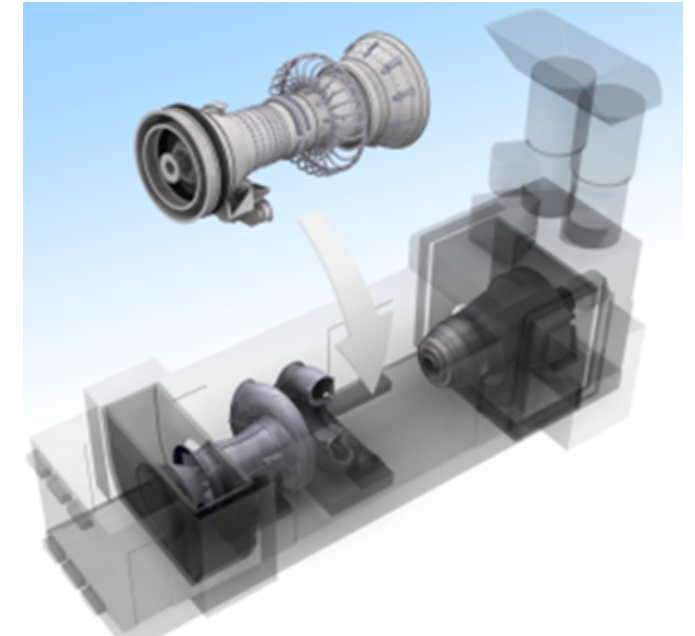
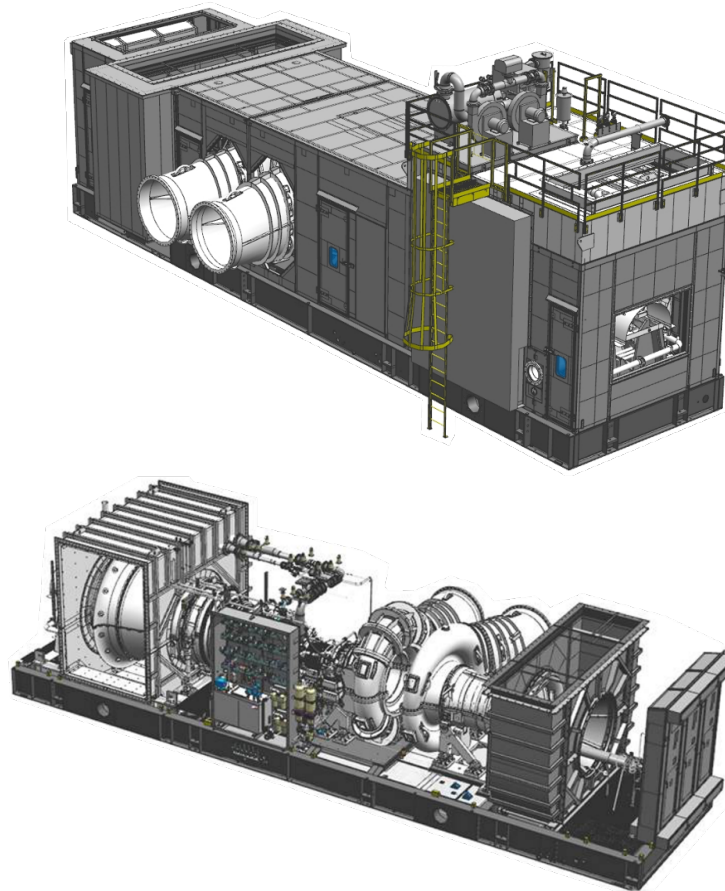

## Optimized package design

For maintenance tasks and supercore exchange in less than 3 days

# Datasheet

## LMS100PB+

### Power generation

<b>Power</b>	MWe	108
<b>Efficiency</b>	%	43
<b>Nox</b>	ppm	25
<b>Exhaust</b>	°C	413
<b>Speed</b>	RPM	3,000/3,600

### Package

<b>LxWxH</b>	m	19x7.3x7
<b>Weight</b>	ton	232

### Mechanical drive

<b>Power</b>	MWe	110
<b>Efficiency</b>	%	44
<b>Nox</b>	ppm	25
<b>Exhaust</b>	°C	410
<b>Speed</b>	RPM	3,429

### Main inspections

<b>HGP</b>	hr	25,000
<b>Major insp.</b>	hr	50,000

### Key features

- Best-in-class simple-cycle efficiency (>44%)
- Minimum CO<sub>2</sub> footprint (55 tons CO<sub>2</sub>/year less than the main competitor at parity of output power)
- Dry low emission combustion system, capable of <25 ppm NOx @ 15% O<sub>2</sub>, at 75–100% load
- Free power turbine speed range: 2,880–3,600 rpm, suitable for
  - Power generation, 50 and 60 Hz with no gearbox
  - Mechanical drive
- More than 40 kN-m breakaway torque capability of the tower turbine demonstrated by test, sufficient to enable pressurized start-ups in LNG applications without a helper motor
- Supercore exchange capability in 3 days to maximize availability

ISO conditions with natural gas fuel, ambient temperature 15°C, no inlet or exhaust losses, sea level, 60% relative humidity. Mechanical Package dimensions driven equipment excluded.

# Modular solution

## Key features

- LMS100PB+ O&G package
- Driven compressors
- Balance of plant
- Intercooler
- Control room
- 52 x 21 m footprint, 25 m height
- 3,000 metric tons total gross weight



Built, commissioned, and tested (optionally at full speed, full power) in Baker Hughes facility



Shipped as a single unit for minimized installation and commissioning activities at customer site